

# BATTERY BACKUP MODULE

# Table of Contents

---

Introduction . . . . . 3

Kit Components . . . . . 5

DC Converter Installation . . . . . 6

Product Identification . . . . . 7

Connection Schematic . . . . . 8

Connections . . . . . 10

    Mains Supply Connections . . . . . 10

    A10 Motor Connections . . . . . 11

    12V Battery Connections . . . . . 12

Commissioning procedure . . . . . 13

Status Indication . . . . . 13

Notes . . . . . 15

** DANGER**

**BATTERIES WILL GIVE OFF HYDROGEN GAS.**

**TO PREVENT POSSIBLE EXPLOSION CAUSED BY IGNITION FROM THE CONTROLLER, KEEP DC CONVERTER ENCLOSURE AND BATTERY ENCLOSURE SEPARATE. IN ADDITION ENSURE THAT THE BATTERY ENCLOSURE IS PROPERLY VENTED.**

** DANGER**

**THE 310V DC SUPPLY IS HAZARDOUS AND POTENTIALLY LETHAL. THE A10 CONVERTER MODULE SHOULD BE INSTALLED AND MAINTAINED BY A QUALIFIED INSTALLER ONLY.**

** IMPORTANT**

**TO SERVICE THE DC CONVERTER PLEASE DISCONNECT THE EXTERNAL BATTERY FROM THE CONVERTER AND ISOLATE THE MAINS SUPPLY AT THE DISTRIBUTION BOARD.**

**(NB. THERE MAY BE A RESIDUAL CHARGE ASSOCIATED WITH THE CAPACITANCE ON THE A10 OPERATOR. TO ENSURE SAFETY WAIT FOR THE RESIDUAL CHARGE ON THE A10 OPERATOR TO DECAY TO SAFE LEVELS.)**

# Introduction

---

The DC Converter allows the A10 gate operator to function with a 12V battery in the absence of AC mains. The DC Converter steps up the 12V battery supply to 310V DC. The inverter drive on the A10 operator then switches the high voltage DC supply to run the three phase induction motor.

## Features

### ON-DEMAND BATTERY BACKUP

The DC Converter differs from a standard Uninterruptible Power Supply (UPS) in that it supplies the power required by the A10 Operator as and when the A10 requires it.

A standard UPS would supply the power required by the A10 Operator the instant the power fails. What if the A10 is not operating? The energy stored in the UPS battery is being wasted unnecessarily.

The DC Converter will not supply the power required by the A10 the instant the power fails. Instead it waits until the A10 is activated and then supplies the power. Thereby making the DC Converter significantly more energy efficient than a standard UPS.

### BATTERY PROTECTION CIRCUITRY

The Converter has built in circuitry that prevents the Converter from damaging the battery when the battery drops into a battery low condition. The battery may be irreparably damaged if the A10 and Converter flatten the battery completely. For this reason the Converter completely disconnects the battery from any current consuming circuitry when the battery voltage drops below the battery low threshold.

### BATTERY-LOW SHUTDOWN

The DC Converter constantly monitors the condition of the battery. If the battery voltage falls below a minimum operating voltage, the Converter discontinues operation.

The shutdown is intelligent in the event that the A10 is active when the battery-low condition is detected. The DC Converter will attempt to wait for the A10 to complete either its opening or closing cycle before shutting down. If the A10 is still active 45 seconds after the Converter detected the battery-low condition, the Converter will shutdown irrespective of where the A10 is in its cycle.

### THERMAL SHUTDOWN

The DC Converter constantly monitors the operating temperature. If the operating temperature exceeds a high-temperature threshold the Converter discontinues operation.

As in the battery-low shutdown, the thermal shutdown is intelligent. The DC Converter will attempt to wait for the A10 to complete either its opening or closing cycle before shutting down. If the A10 is still active 45 seconds after the Converter detected the high-temperature condition, the Converter will shutdown irrespective of where the A10 is in its cycle.

The Converter will wait for the temperature to cool to acceptably low operating conditions before resuming operation.

### BROWN-OUT POWER FAILURE DETECTION

The Converter monitors the Mains voltage for more than just power failures. It is able to sense and compensate for Brown-Out power failures too.

Under certain Brown-Out conditions the A10 operator will continue to operate. The concern is the A10 is operating outside of the voltage and particularly current specifications - This could result in irreparable damage to the A10 operator. The Converter addresses this concern, supplementing the Mains supply and compensating for any voltage irregularities.

---

## **POWER SAVING MODE**

The Converter implements various power saving techniques to extend the life of the battery when the Converter is in an idle state. These power saving strategies come into play when Mains fails (while Mains is present there is no need to implement these strategies since the battery is being charged).

Reducing the current consumed by the Converter when the system is in an idle state extends the time that battery-backup is available. This is critical to the user - A battery-backup unit is of little value to the user if the battery is flat before the user even operates the gate under power failure conditions.

## **AUTONOMOUS OPERATION**

The Converter is designed to be resilient to fault conditions. If the Converter senses a fault it shuts down and resumes normal operation after a specified period of time. This allows for completely autonomous operation of the Converter. There is no need for the user to reset the Converter once the fault is cleared.

## **A10 OVERLOAD PROTECTION**

The Converter monitors the output voltage that it supplies to the A10 Operator. If the A10 Operator attempts to draw too much current from the Converter, the Converter shuts the supply down. This prevents the Converter and the A10 from operating out of specification.

Normal Converter operation resumes after a period of 2 minutes.

The integrity of the circuitry monitoring the Converter output voltage is also checked in this manner. This prevents the Converter from supplying the incorrect supply voltage to the A10 in the event that the Converter fails.

## **A10 RUN FAULT PROTECTION**

The Converter intelligently monitors the A10 Operator. Under normal conditions the A10 Operator requires the Converter to run while the gate is opening or closing. However if the A10 Operator fails then it is possible that a request could be made by the A10 for the Converter to run continuously for a period longer than 2 minutes. Under these failure conditions, the Converter immediately throttles the duty cycle.

If the fault is persistent, the Converter will shut down completely. If the fault clears itself at any stage, the Converter will immediately resume normal operation.

This prevents a faulty A10 Operator from running the Converter continuously and flattening the battery unnecessarily.

# Kit Components

**DC Converter, incl 2.5A charger, ex battery (DC\_CON10V2)**

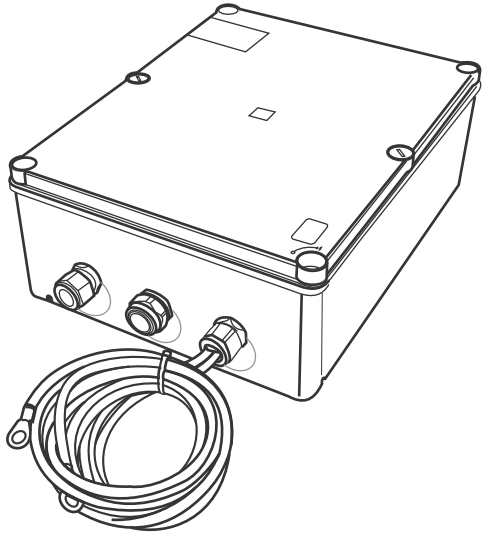
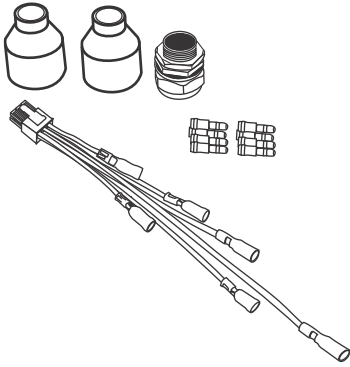

**Battery LM, 12V, 40A/H (CP5)  
(Order separately)**

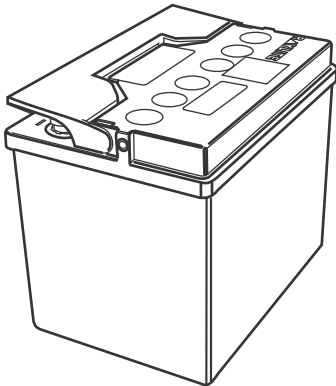

**Enclosure for 40A/H battery (CP6)  
(Order separately)**

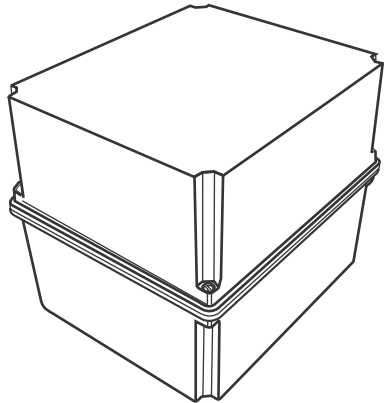

Fig. 1 Kit Components

# DC Converter Installation

**⚠ DANGER**

**BATTERIES WILL GIVE OFF HYDROGEN GAS.**

**TO PREVENT POSSIBLE EXPLOSION CAUSED BY IGNITION FROM THE CONTROLLER, KEEP DC CONVERTER ENCLOSURE AND BATTERY ENCLOSURE SEPARATE. IN ADDITION ENSURE THAT THE BATTERY ENCLOSURE IS PROPERLY VENTED.**

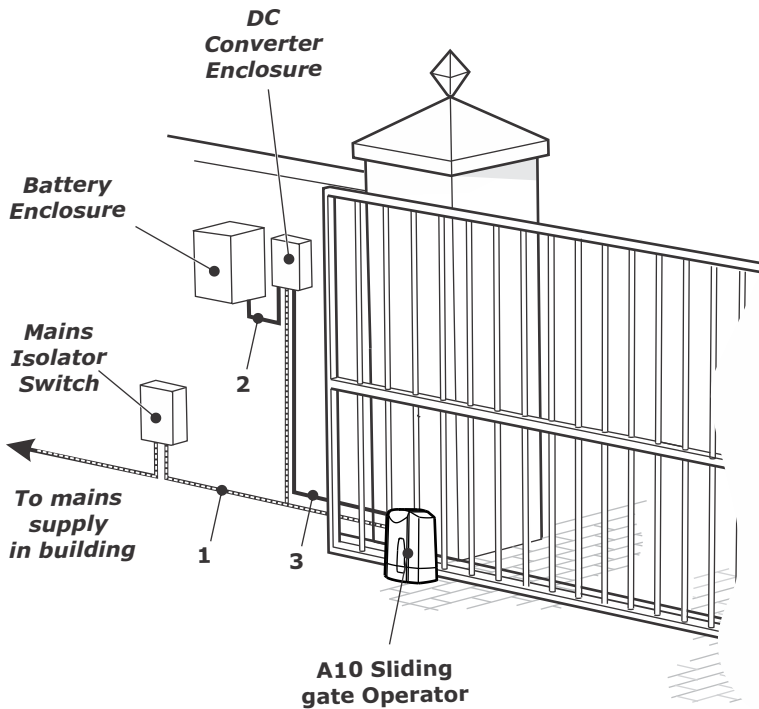

1. 220V AC mains cable (3 core LNE 1,5mm<sup>2</sup>) via mains isolator switch (order code: EISOL20AE1)
2. 12V Battery cable (supplied with the DC Converter kit)
3. 7 Core armoured cable required to connect the DC converter to the A10 sliding gate operator (order code: CABLE07ARM/metre)

Fig. 2 DC Converter Installation

# Product Identification



Fig. 3 Product Identification

# Connection Schematic

Figure 4 is a schematic diagram for the DC Converter and the A10. It shows the different inputs and outputs of the DC Converter and how the outputs interface with the A10 Inverter and Logic Controller.

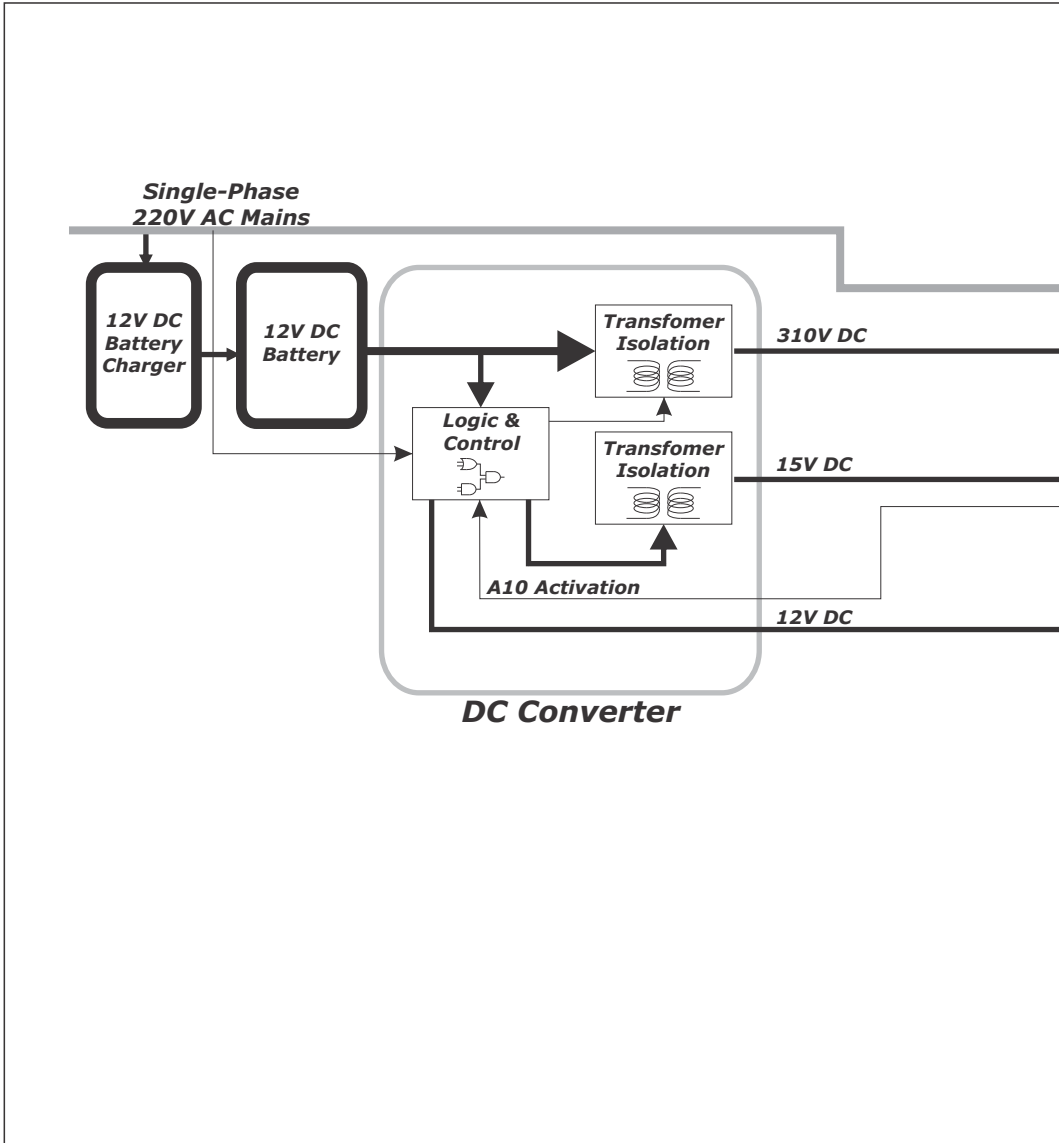
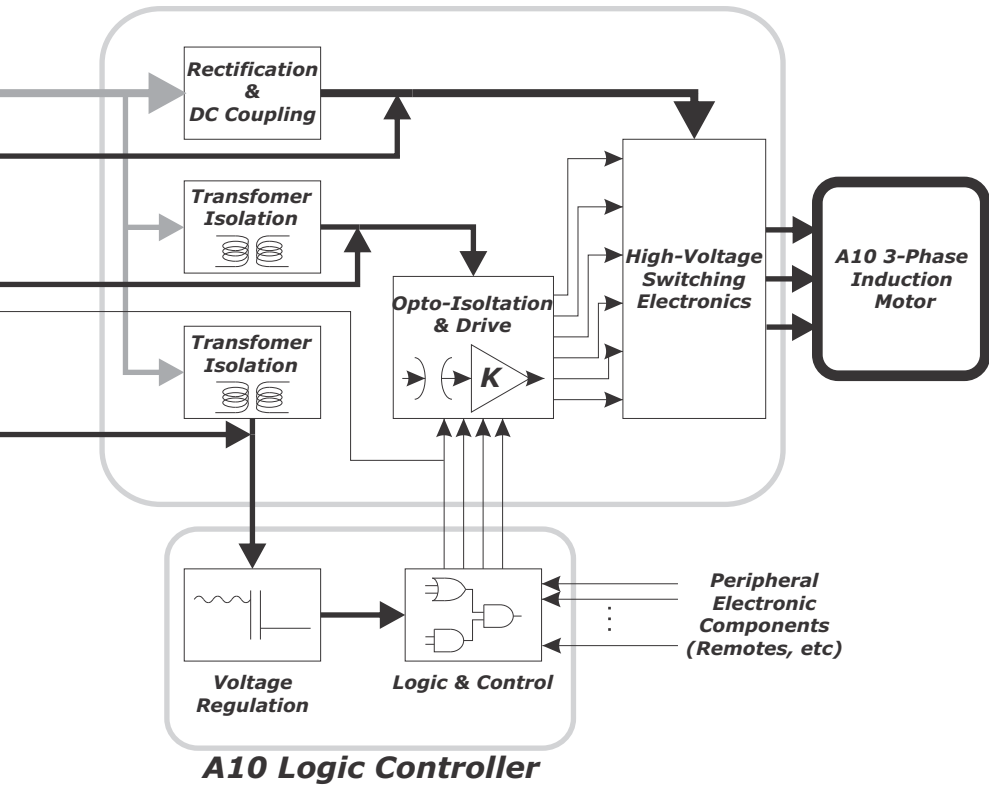

Fig. 4 DC Converter and A10 Schematic Diagram



## ***A10 Inverter Electronics***



# Connections

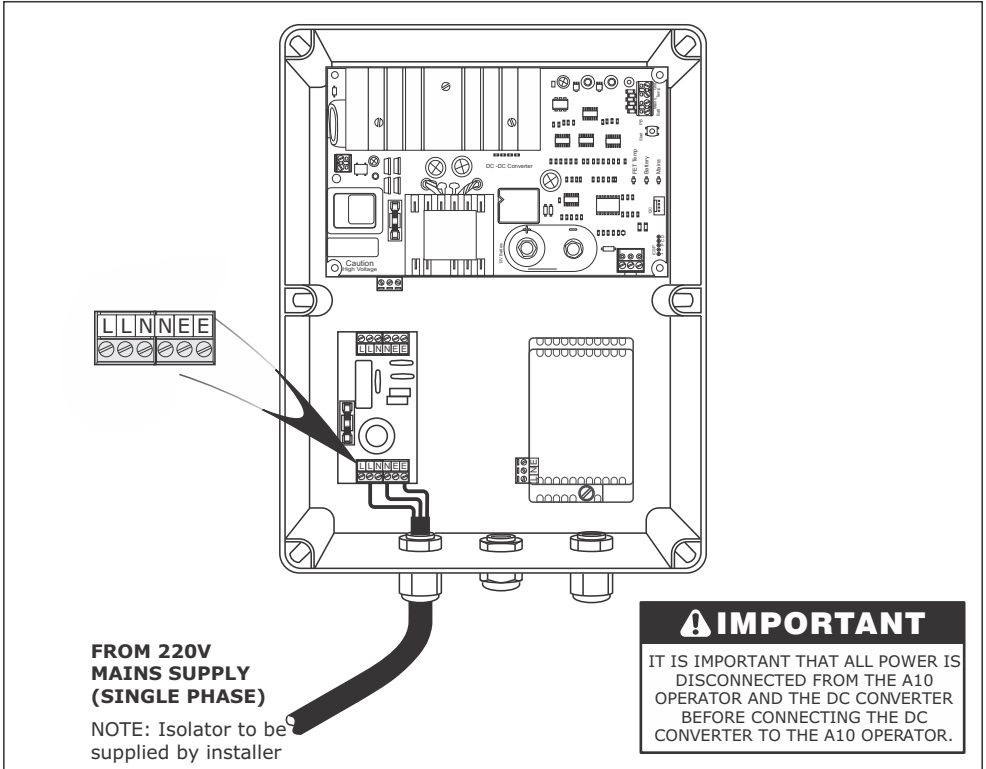

Fig. 5 DC Converter Power Connections

1. Make sure that the mains supply to the system is isolated before proceeding with any connections.
2. Connect the mains supply to the surge protection module of the DC converter unit as shown in Fig 5.



The DC converter must be connected to the same mains supply as the A10 operator.

In addition to supplying power to the battery charger, the mains supply is required for the DC converter to sense a mains fail condition on the A10.

3. Terminate both ends of the 7 core cable that links the DC Converter to the A10 operator as shown in Fig 6.
  - On the DC Converter side the individual wires terminate directly into the screw terminals provided.
  - On the A10 operator side, start by trimming the length of each wire so that they correspond with the wire lengths of the DC harness provided for a compact joint.

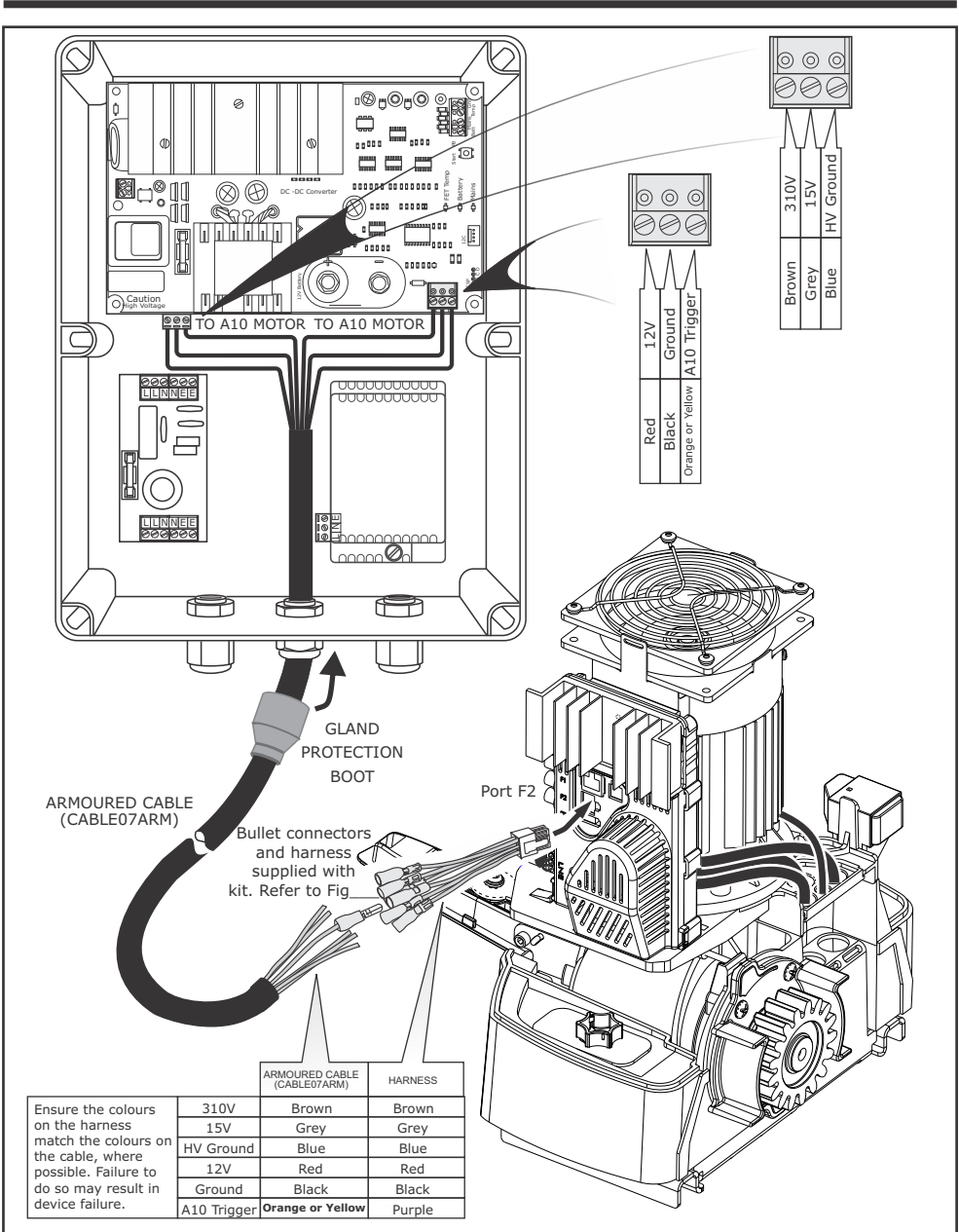

Fig. 6 A10 Operator Connections

# 12V Battery Connections

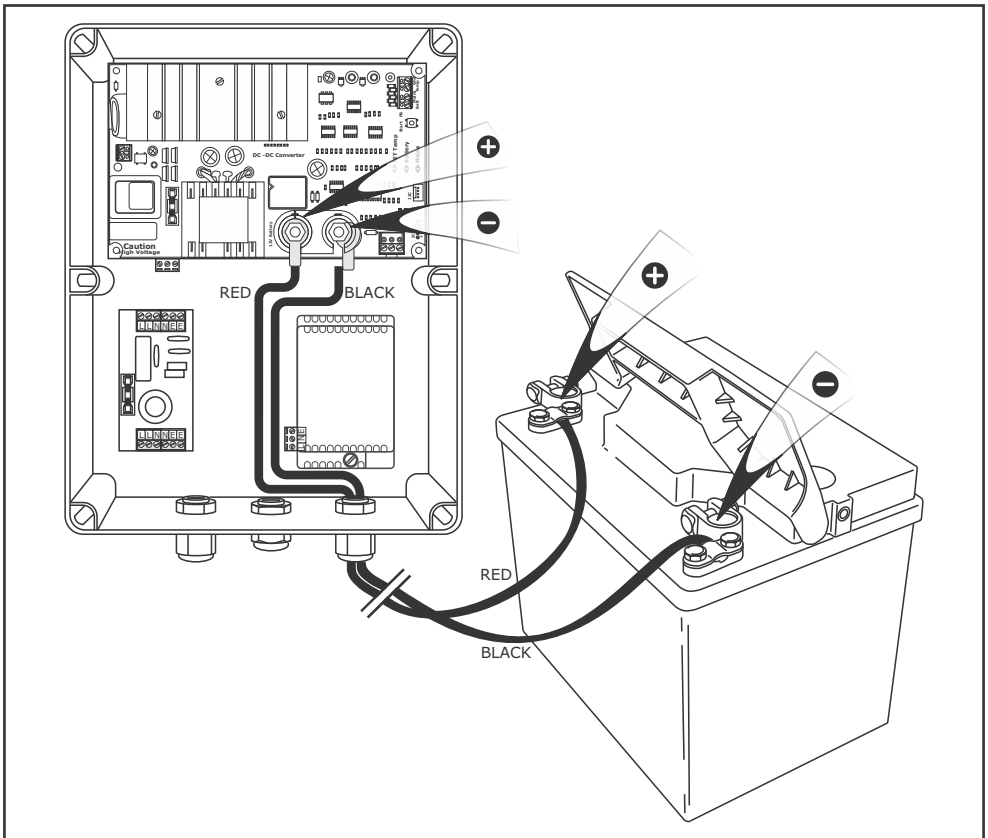

Fig. 7 12V Battery Connections

Then securely crimp the male bullet connectors onto the wires adhering to recommended colour coding schedule. Make sure that with each termination there are no exposed wires.

Securely press each bullet connector together and finish off by taping up the bullet connector junction with insulation tape.

4. Make sure that there is no residual charge left in the A10 operator before plugging in the mini-fit connector of the DC converter harness into the inverter as shown in Fig 6. If in doubt, leave the A10 operator disconnected from the power for a minimum of 10 minutes before connecting the DC Converter.
5. As shown in Fig 7, bolt the battery leads onto the DC Converter making sure that the RED lead is connected to the POS + terminal and likewise the BLACK lead to the NEG - terminal.
6. Terminate the battery leads onto the battery again noting the correct battery polarity.

# Commissioning Procedure

1. Switch on 220V AC mains to system (the same supply must connect to both the DC converter and A10).
2. Check that the GREEN Mains Presence LED on the DC converter lights up to indicate mains present.
3. Check that the YELLOW Battery Indication LED flashes intermittently – note status indication diagram, see Table A below to determine approximate charge in battery.
4. Test unit by failing mains and operate A10. Check that the A10 operates normally.
5. Note that the ON to OFF time of the YELLOW Battery Indication LED changes to indicate battery capacity dropping due to A10 usage.
6. With extended usage, note that the RED Temperature Status LED starts to flash as per status indication, see Table C on page 14 to indicate unit starting to warm up.
7. Restore mains and ensure that the GREEN Mains Presence LED comes on.
8. Test that A10 continues to operate off normal mains supply.

## Status Indication

### Status Indication LED's

The DC Converter status is indicated using three LED's. The LED's indicate Battery Voltage (Yellow LED), Mains Voltage (Green LED) and DC Converter temperature (Red LED)

Each TABLE shows how for the different statuses the respective LED indicates.

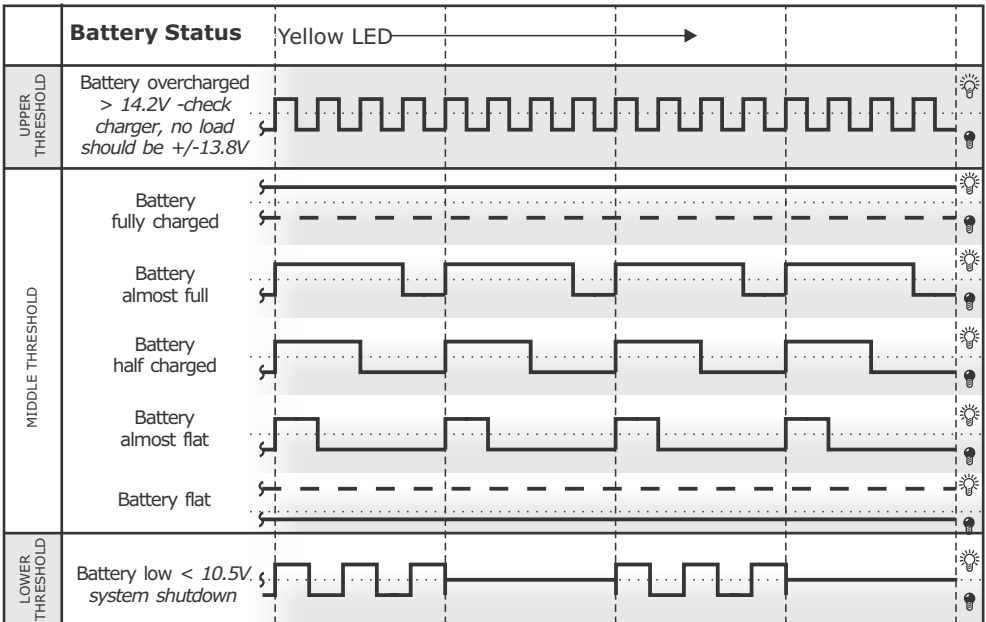

Table A: Yellow LED - Battery Voltage Indication

# Status Indication

		220V Mains Status		Green LED	
UPPER THRESHOLD	Over-voltage >260V - check mains supply				
	Mains at nominal voltage				
MIDDLE THRESHOLD	Mains brownout condition level 1				
	Mains brownout condition level 2				
	Mains brownout condition level 3				
LOWER THRESHOLD	Mains off			LED OFF	

Table B: Green LED - Mains Indication

		Temperature Status		Red LED	
UPPER THRESHOLD	Thermal overload System shutdown				
	Reaching max temperature threshold				
MIDDLE THRESHOLD	Temperature rising level 3				
	Temperature rising level 2				
	Temperature rising level 1				
LOWER THRESHOLD	Temperature below minimum indication			LED OFF	

Table C: Red LED - Temperature Indication





**Sharecall 0860-CENTURION (0860 236 887)**  
**Head Office: +27 11 699 2400**

**Sharecall Technical Support 0861 003 123 or**  
**+27 11 699 2481**  
from 07h00 to 18h00 (GMT+2)

(Sharecall numbers applicable when dialed from within South Africa only)



0.07.A.0124\_22072013

**[www.centsys.com](http://www.centsys.com)**