

VERT-X Mechanical Installation Manual



VERT-X[®]



Company Profile



In-house R&D development team



100% testing of products

Manufacture to international quality standard ISO 9001:2008



After-sales multi-language Technical Support from 07h00 to 18h00 UTC+2 Monday to Friday



Sales and technical support to Africa, Europe, Asia, the Americas, Australia and the Pacific

Centurion Systems (Pty) Ltd reserves the right to make changes to the products described in this manual without notice and without obligation to notify any persons of any such revisions or changes. Additionally, **Centurion Systems (Pty) Ltd** makes no representations or warranties with respect to this manual. No part of this document may be copied, stored in a retrieval system or transmitted in any form or by any means electronic, mechanical, optical or photographic, without the express prior written consent of **Centurion Systems (Pty) Ltd**.



Contents

**SAFETY
FIRST**

IMPORTANT SAFETY INSTRUCTIONS

page 6

| | |
|--|---------|
| 1. General Description | page 9 |
| 2. Icons Used in this Manual | page 10 |
| 3. Specifications | page 11 |
| 3.1. Physical Dimensions | page 12 |
| 3.2. Technical Specifications | page 12 |
| 3.3. V-Series Controller | page 13 |
| 3.4. Lightning Protection | page 14 |
| 3.5. Maximum Allowable Gate Mass | page 14 |
| 3.6. Maximum Allowable Gate Coverage for different Wind Speeds | page 14 |
| 4. Product Identification | page 15 |
| 5. Required Tools and Equipment | page 17 |
| 6. Preparation of Site | page 18 |
| 6.1 General Considerations for the Installation | page 18 |
| 6.2 Determine Gate Opening Angle | page 19 |
| 6.3 Key Terms Used in this Section | page 20 |
| 6.4 Inward Opening Installation - 90° or Less | page 20 |
| 6.5 Inward Opening Installation - 100° | page 21 |
| 6.6 Hinge Depth on Gate | page 22 |
| 6.7 Wall Bracket Mounting Methods | page 23 |
| 6.8 Gate Bracket Mounting | page 25 |
| 7. Cabling Requirements | page 26 |
| 8. Critical Installation Checklist | page 27 |
| 9. Operator Installation - Inward Opening Gates | page 28 |
| 9.1. Key Terms Used in this Section | page 28 |
| 9.2. Installation Tables - Inward Opening | page 28 |
| 9.3. Physical Installation - Inward Opening | page 30 |

| | |
|--|---------|
| 10. Operator Installation - Outward Opening Gates | page 40 |
| 10.1. Key Terms Used in this Section | page 40 |
| 10.2. Installation Tables - Outward Opening | page 40 |
| 10.3. Physical Installation - Outward Opening | page 42 |

FAST TRACK Mechanical Setup

These quick steps are for the experienced installer who needs a checklist to get a standard installation up and running in the minimum amount of time.

Detailed installation features and functions are referred to later on in this manual.

STEP 1

Gather Required Tools and Equipment

STEP 2

Heed Necessary Site Considerations

STEP 3

Determine Installation Type

- Inward Opening Installation
- Outward Opening Installation

STEP 4

Check Cabling Requirements

STEP 5

Determine the Gate Swing Angle

STEP 6

Mount the Gate and Wall Bracket(s)

STEP 7

Install Operator

STEP 8

Mount Controller Enclosure

IMPORTANT SAFETY INSTRUCTIONS

ATTENTION

To ensure the safety of people and possessions, it is important that you read all the following instructions.

Incorrect installation or incorrect use of the product could cause serious harm to people and pets.



The installer, being either professional or DIY, is the last person on the site who can ensure that the operator is safely installed, and that the whole system can be operated safely.

Warnings for the Installer

CAREFULLY READ AND FOLLOW ALL INSTRUCTIONS before beginning to install the product.

- All installation, repair, and service work to this product must be done by a suitably qualified person
- Do not activate your gate opener unless you can see it and can determine that its area of travel is clear of people, pets, or other obstructions
- **NO ONE MAY CROSS THE PATH OF A MOVING GATE.** Always keep people and objects away from the gate and its area of travel
- **NEVER LET CHILDREN OPERATE OR PLAY WITH THE GATE CONTROLS,** and do not allow children or pets near the gate area
- Secure all easily-accessed gate opener controls in order to prevent unauthorised use of the gate
- Do not in any way modify the components of the automated system
- Do not install the equipment in an explosive atmosphere: the presence of flammable gas or fumes is a serious danger to safety
- Before attempting any work on the system, switch off electrical power and disconnect the batteries
- The mains power supply of the automated system must be fitted with an all-pole switch with contact opening distance of 3mm or greater. Use of a 5A hydraulic breaker with all-pole circuit break is recommended
- Make sure that an earth leakage circuit breaker with a threshold of 30mA is fitted upstream of the system
- Never short-circuit the battery and do not try to recharge the batteries with power supply units other than that supplied with the product, or manufactured by Centurion Systems (Pty) Ltd
- Make sure that the earthing system is correctly constructed, and that all metal parts of the system are suitably earthed

- Safety devices must be fitted to the installation to guard against mechanical movement risks such as crushing, dragging and shearing
- It is recommended that at least one warning indicator light be fitted to every system
- Always make sure that the warning signs are fitted so that they are visible from inside and outside of the gate
- The installer must explain and demonstrate the manual operation of the gate in the case of an emergency, and must hand the User/Warnings guide over to the user
- The installer must explain these safety instructions to all persons authorised to use this gate, and be sure that they understand the hazards associated with automated gates
- Do not leave packing materials (plastic, polystyrene, etc.) within reach of children as such materials are potential sources of danger
- Dispose of all waste products such as packing materials, worn-out batteries, etc, according to local regulations
- Always check the obstruction detection system and safety devices for correct operation
- Neither Centurion Systems (Pty) Ltd, nor its subsidiaries, accepts any liability caused by improper use of the product, or for use other than that for which the automated system was intended
- This product was designed and built strictly for the use indicated in this documentation. Any other use, not expressly indicated here, could compromise the service life/operation of the product and/or be a source of danger
- Everything not expressly specified in these instructions is not permitted



- **Never run the operator directly from the battery! Doing so will cause damage to the operator. Only run the operator from the V-Series Controller**
- **A moving gate can cause serious injury or death! Keep clear! The gate may move at any time! Do not allow children to play in the area of travel of the gate or operate the gate**

This section has been left blank intentionally.

1. General Description

The **VERT-X** operator has been designed to safely and cost-effectively automate a domestic swing gate.

Combining an innovative open-nut drive system, advanced diagnostic capabilities and functionality, rugged die-cast aluminium construction and exceptional aesthetics for a wholly unobtrusive installation, **VERT-X** is positioned firmly at the apex of swing gate automation. In addition, the engineering team behind its design has invested considerable effort ensuring that the operator is as easy to install as it is powerful, and as reliable as it is good-looking.

The fail-safe and fully redundant position and collision detection system has been designed and tested to set the standard in safety of operation and to provide an unparalleled level of reliability and durability in operation.

The gate travel limits are managed by a sealed double-redundant opto-electronic system that has been designed not only to ensure ultra-reliable operation, but also to ensure precise position and trajectory control. This enables very accurate and reliable collision detection to ensure safe operation even under trying conditions.

The control card has been designed to be easy and intuitive to use with helpful instructions on the status of the operation during and after the installation. It also has a built-in diagnostic procedure that can verify every aspect of the control card onsite.

Some of the advanced features offered by the **V-Series Controller** are:

- Fully automated single-button Limit Setup for single and double swing gates
- Full graphics LCD display provides an intuitive user interface with built-in diagnostics to speed up and simplify the installation process
- Separate safety inputs for infrared beams on both the closing and opening directions of the gate
- Advanced closed-loop speed control to maintain safe and reliable operation of gates even under windy conditions
- Fully configurable gate Run Profiles
- Selectable and adjustable Autoclose with pushbutton override
- Pedestrian (Partial) opening with automatic closure
- Free-exit input
- Positive Open and Close Modes for gate locks and electric fence contacts
- Support for Inward and Outward opening gates
- Multiple Modes of Operation
- Solenoid lock drive output up to 2A
- Holiday Lockout
- A status LED output to indicate the gate status remotely
- Pillar Light control
- Leaf delay is selectable for either gate leaf
- Onboard code-hopping receiver with selective adding and deleting of remotes

2. Icons Used in this Manual



This icon indicates tips and other information that could be useful during the installation.



This icon denotes variations and other aspects that should be considered during installation.



This icon indicates warning, caution or attention! Please take special note of critical aspects that MUST be adhered to in order to prevent injury.

3. Specifications

3.1. Physical Dimensions

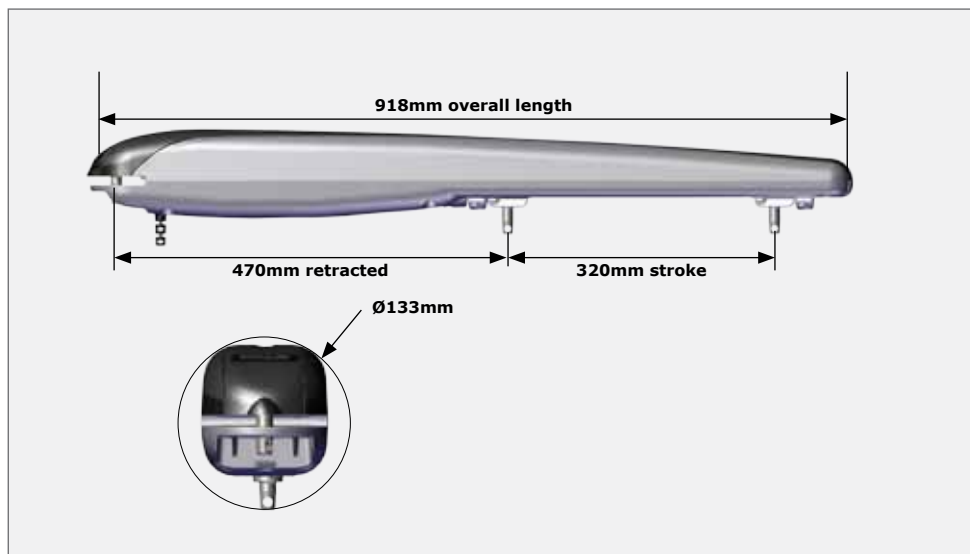

FIGURE 1. VERT-X OVERALL DIMENSIONS

3.2. Technical Specifications - VERT-X Operator

| | Light-Industrial |
|--|---|
| Input voltage ¹ | 90V - 240V AC \pm 10%, 50/60Hz |
| Motor voltage | 12V DC |
| Motor power supply | Battery-driven (standard capacity - 7Ah) ² |
| Battery charger | CP84SM - 1.8A @ 13.8V |
| Current consumption (Mains) | 170mA |
| Current consumption (motor at rated load) | 3A |
| Current consumption (motor at max load) | 13A |
| Operator push force - maximum | 220kgf |
| Operator stroke - maximum | 320mm |
| Operator speed (at rated load) | 28mm/sec |
| Typical gate opening time (90°) ³ | <11 sec |
| Manual override | Key release ⁴ |
| Maximum number of operations per day | 250 |
| Design life | 150,000 cycles |
| Duty cycle (Mains present) ^{5 6} | 60% |
| Operations in Standby over 24 hours (with fully charged 7Ah battery) ⁷ | 300 |
| Collision sensing | Electronic |
| Operating temperature range | -15°C to +50°C |
| Mass of operator packed (excluding battery) | |
| Single kit ⁸ | 10kg |
| Double kit ⁹ | 18kg |

TABLE 1

1. Can operate off a solar supply, consult your reseller for assistance
2. Can increase battery capacity for longer standby times
3. Assumes that full stroke of operator is used
4. Each operator comes with a unique set of keys
5. Based on 25°C ambient temperature and unit not in direct sunlight
6. Based on an operator push force of less than 50% of rated
7. Based on double kit excluding Infrared Safety Beams
8. Single kit contains one operator and Wall Box
9. Double kit contains two operators and one Wall Box

3.3. V-Series Controller

| | |
|-----------------------------------|-------------------------------------|
| Maximum motor current per channel | 15A (fused) |
| Maximum input voltage | 18V DC |
| Standby current draw | 48mA |
| Maximum solenoid current draw | 2A DC |
| Maximum auxillary output current | 3A (Resettable Electronic Fuse) |
| Collision detection | Current sense and redundant optical |
| Position and trajectory | Redundant optical |
| Temperature range | -20°C to +60°C |

TABLE 2

3.4. Lightning Protection

The **V-Series** electronic controller utilises the same proven surge protection philosophy that is used in all our products. While this does not guarantee that the unit will not be damaged in the event of a lightning strike or power surge, it greatly reduces the likelihood of such damage occurring. The earth return for the surge protection is provided via the mains power supply earth. In order to ensure that the surge protection is effective, it is essential that the unit is properly earthed.

3.5. Maximum Allowable Gate Mass and coverage

| Maximum Allowable gate Mass | | | | |
|-----------------------------|------------|----------|------------|----------|
| Length (m) | Up to 1.5m | Up to 2m | Up to 2.5m | Up to 3m |
| Mass (kg) | 600kg | 335kg | 215kg | 150kg |

TABLE 3

An electronic lock can be fitted to improve the security of the system

3.6. Maximum Allowable Coverage in Wind Speeds

| Maximum Allowable Coverage in Wind Speeds | | | | |
|---|----------------------------|------------|------------|------------|
| Length (m) | Up to 1.5m | Up to 2m | Up to 2.5m | Up to 3m |
| Height (m) | Up to 1.8m | Up to 1.8m | Up to 1.8m | Up to 1.8m |
| Coverage | Maximum Wind Speeds (km/h) | | | |
| 25% | 91 | 68 | 55 | 45 |
| 50% | 64 | 48 | 39 | 32 |
| 75% | 52 | 39 | 31 | 26 |
| 100% | 45 | 34 | 27 | 23 |

TABLE 4

4. Product Identification

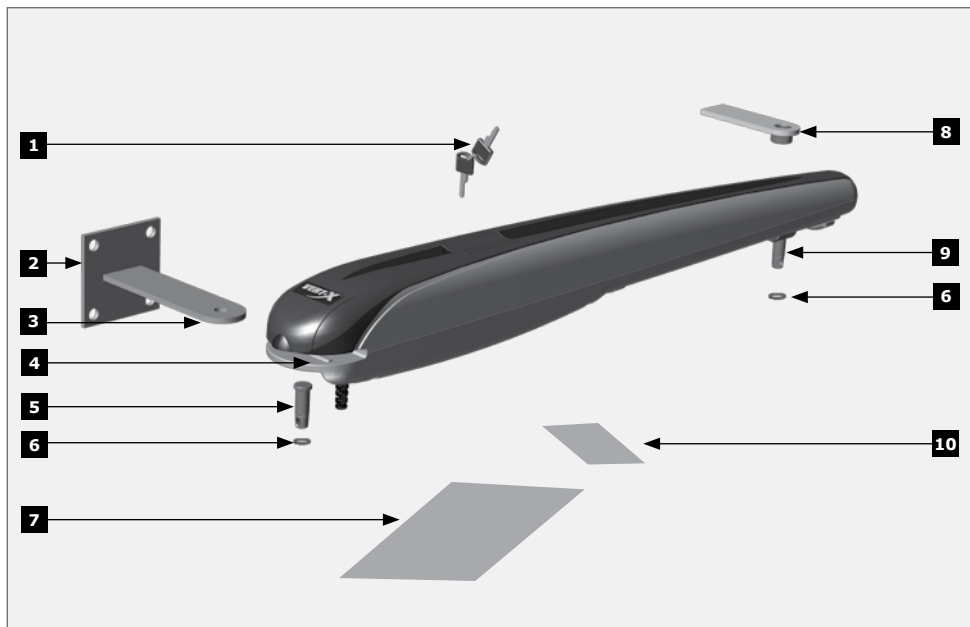

FIGURE 2. PRODUCT IDENTIFICATION

- | | |
|--|--------------------------------------|
| 1. Gate operator keys ¹ | 6. 14mm snap rings |
| 2. Wall Bracket mounting plate | 7. Mechanical Installation Manual |
| 3. Wall Bracket | 8. Gate Bracket welded assembly |
| 4. VERT-X gate operator (complete assembly) | 9. Gate Bracket pin (optional extra) |
| 5. Wall Bracket pin | 10. Gate warning decal |
1. Keys are specific to each operator - key number must be recorded

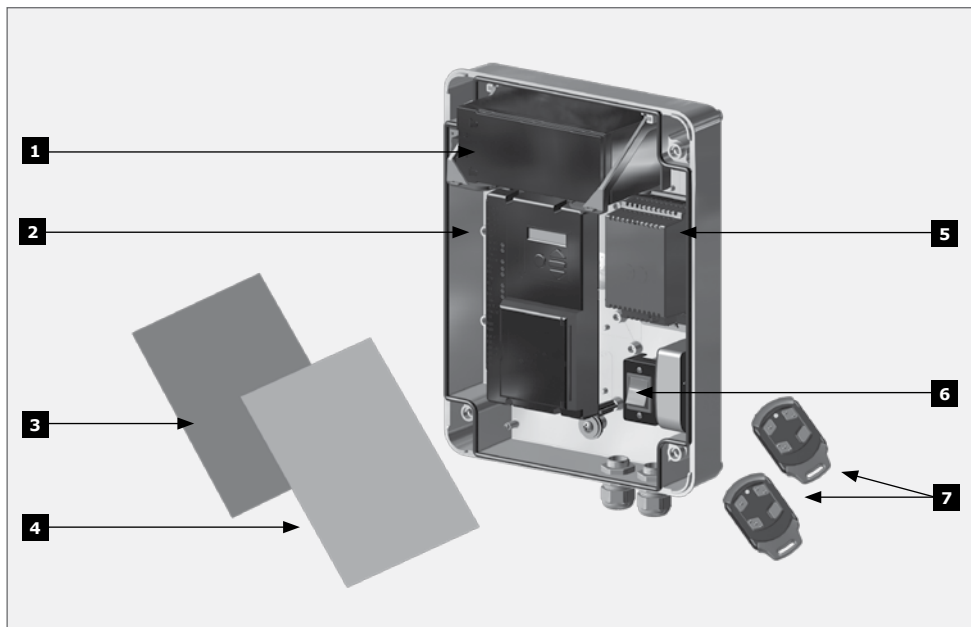

FIGURE 3. V-SERIES WALL BOX INCLUDING CHARGER AND CONTROLLER

- 1. 12V 7.2Ah Battery1
 - 2. **V-Series** Controller with Built-in Receiver
 - 3. **V-Series** User Guide
 - 4. **V-Series** Electrical Setup Commissioning Guide
 - 5. CP84SM Battery Charger
 - 6. Isolator
 - 7. Code-hopping Remote Controls
1. Batteries can be of a larger capacity for longer power failure autonomy and are not included in the kit. Consult your local authorised dealer for assistance

5. Required Tools & Equipment



FIGURE 4

6. Preparation of Site

6.1. General Considerations for the Installation:

Always recommend the fitment of additional safety equipment such as safety edges and Safety Beams (i5 or Photon), for additional protection against entrapment or other mechanical risks

Check that no pipes or electrical cables are in the way of the intended installation

Check that enough space is available for the gate operator with the gate in the required open position (see Figure 6)

If the swing gate leaf is longer than 2.5 metres, ensure that an electric lock can be fitted¹

For security reasons, never fit an operator on the outside of the gate, where the public has access to it (refer to the instructions for an Outward-opening swing gate)

Never run an operator directly off the 12V battery

Install the gate operator only if:

- It will not pose a hazard to the public
- There is sufficient clearance to a roadway and/or public thoroughfares
- The installation will meet all municipal and/or local authority requirements once completed
- The gate mass, leaf width, allowable wind loading and application is within the operator specifications (refer to the specification tables)
- The gate is in good working order, meaning:
 - That it swings freely;
 - Does not move on its own if left in any position;
 - Each gate leaf is strong and rigid;
- Once installed, there is sufficient clearance between moving parts when opening and closing to reduce the risk of personal injury and entrapment
- Pushbuttons or Keyswitches, when required, must be positioned so that the gate is in line of sight of the operator

1. Electric locks are recommend for most swing gate installations where greater security and/or resistance to strong winds is required

6.2. Determine Gate Opening Angle

Use this procedure to accurately determine the gate opening angle:

6.2.1. Step 1

Close the gate and measure a distance of one metre from the centreline of the gate hinge.

Make a mark on the ground.

6.2.2. Step 2

Open the gate and measure a distance of one metre along the gate from the centreline of the gate hinge.

Make another mark on the ground.

Measure the distance on the ground between the two marks (Z).

Using this Z-Value, determine the gate opening angle from the table below.

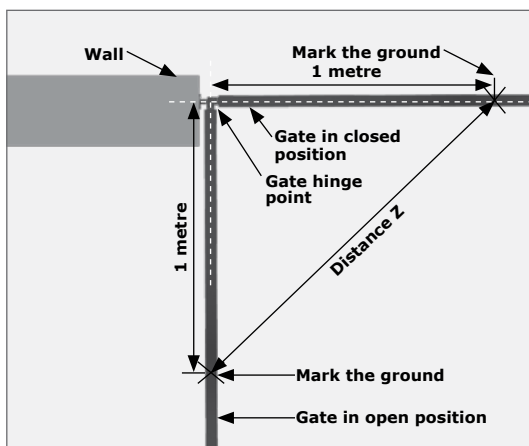

FIGURE 5

6.2.3. Step 3

Gate opening angle based on Z-Value

| Z-Value from | To | Use gate swing angle of |
|---|--------|-------------------------|
| 1000mm | 1133mm | 60° - 69° |
| 1147mm | 1272mm | 70° - 79° |
| 1286mm | 1402mm | 80° - 89° |
| 1414mm | 1475mm | 90° - 95° |
| 1486mm | 1532mm | 96° - 100° |
| Z-Values greater than 1532mm ¹ | | |

TABLE 5

1. The **VERT-X** operator is designed for a maximum gate opening angle of 100°.

6.3. Key Terms Used in this Section

6.3.1. Pillar maximum

The maximum allowable distance measured from the centre of the gate hinge to the edge of the pillar.

6.3.2. Wall minimum

This value denotes the minimum amount of space needed to install the operator and is measured from the side wall to the gate when the gate is in the open position.

6.4. Inward Opening Installation - 90° or less

Figure 6 shows the minimum wall clearance and maximum pillar to gate hinge point distance for an inward opening gate leaf opening to an angle of 90° or less.

The pillar to gate hinge point maximum ensures that the operator does not foul against the pillar when installed. The minimum wall clearance ensures that there is enough space to install the operator according to the installation tables.

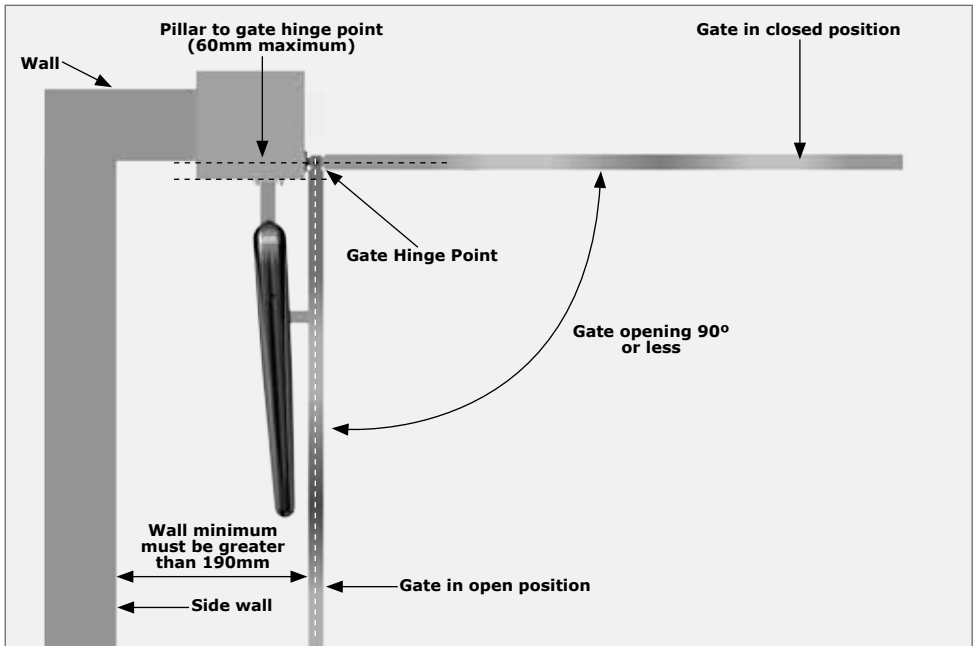

FIGURE 6. SIDE WALL LIMITATION FOR A 90° INWARD OPENING GATE

6.5. Inward Opening Installation - 100°

Figure 7 shows the minimum wall clearance and maximum pillar to gate hinge point distance for an inward opening gate leaf opening to an angle of 100°.

The pillar to gate hinge point maximum ensures that the operator does not foul against the pillar when installed. The minimum wall clearance in the case of the 100° opening ensures that the gate does not run into the wall.

- For gates 1.0m to 2.0m long, the minimum wall clearance is 370mm
- For gates 2.0m to 3.0m long, the minimum wall clearance is 540mm

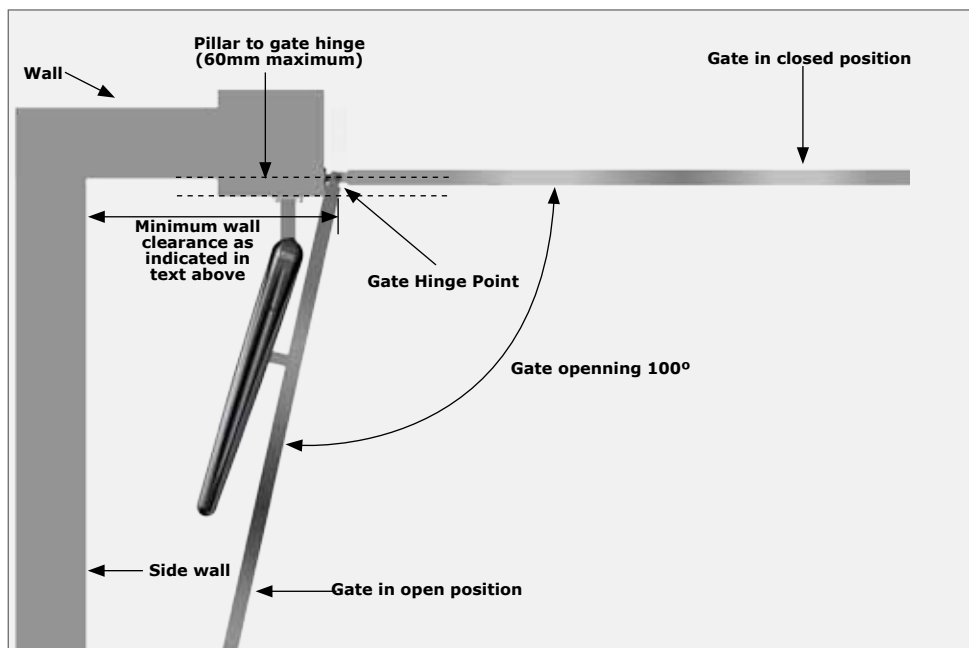

FIGURE 7. SIDE WALL LIMITATION FOR A 100° INWARD OPENING GATE

6.6. Hinge Depth on Gate

Due to the operator body being a fixed length and the operator body extending past the maximum travel position of the Gate Bracket pin, the operator can foul against the gate during operation if the unit is not installed correctly. Before installing the operator, ensure that the hinge depth in relation to the gate face is no more than 30mm.

This will ensure that the front end of the operator does not foul against the gate (see Figure 9.)



A gate hinge depth greater than 30mm will reduce the E-value (refer to Section 9) of the installation which, in turn, may result in the operator fouling against the gate during operation. In the unlikely event that a hinge depth greater than 30mm is measured (most gates will have a hinge depth of less than 30mm, with the exception of gates made from very thick material), the hinges must be ground off and repositioned so as to ensure the hinge point is less than 30mm from the gate face.

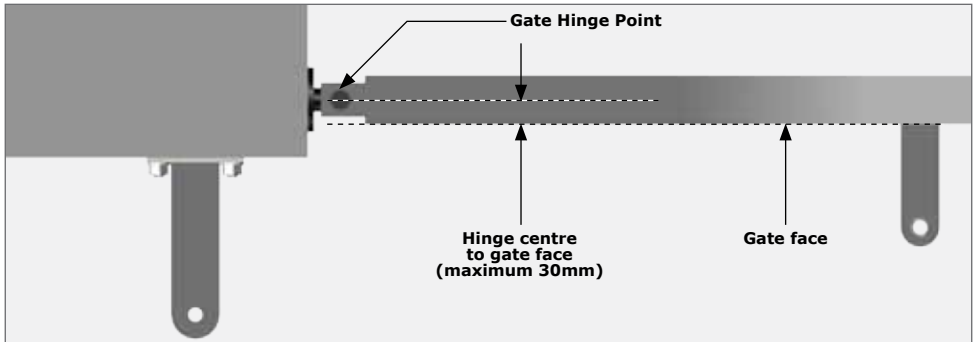

FIGURE 8. MAXIMUM GATE HINGE DEPTH

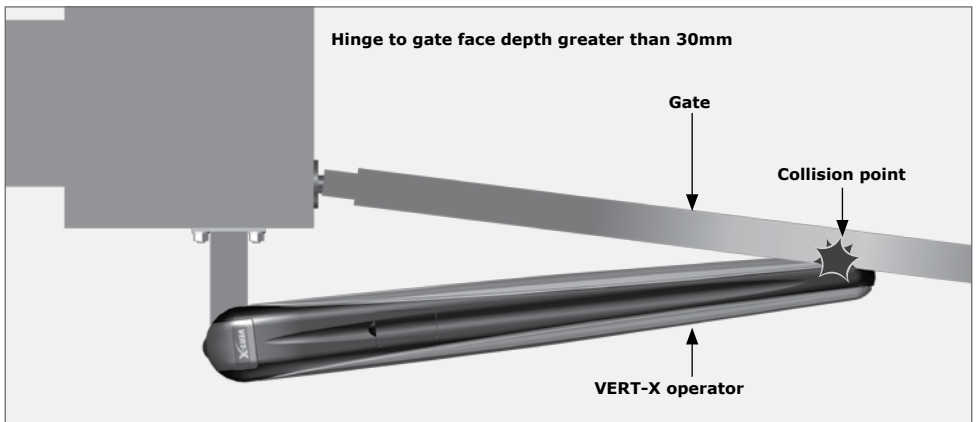

FIGURE 9. OPERATOR COLLIDING WITH GATE

6.7. Wall Bracket Mounting Methods

For reliable operation, it is important to ensure that the way the operator is secured to the wall takes into account the strength of the pillar, the size of the gate and how frequently the gate will be used.

6.7.1. Through-Wall

Applications:

- Pre-fabricated walling
- For heavy gates operating frequently, use this method

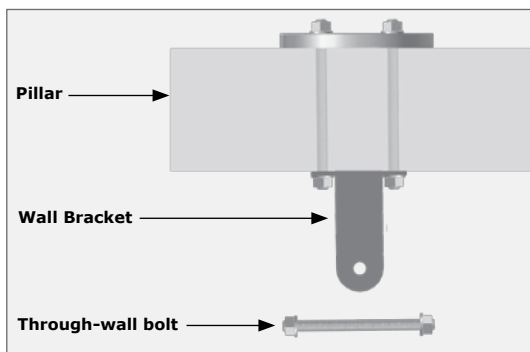

FIGURE 10. THROUGH-WALL

6.7.2. Chemical Anchors

Applications:

- Masonry pillars
- Frequently use

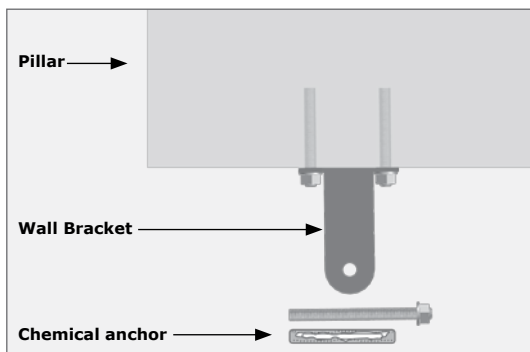

FIGURE 11. CHEMICAL ANCHORS

6.7.3. Welding

Application:

- Steel pillars

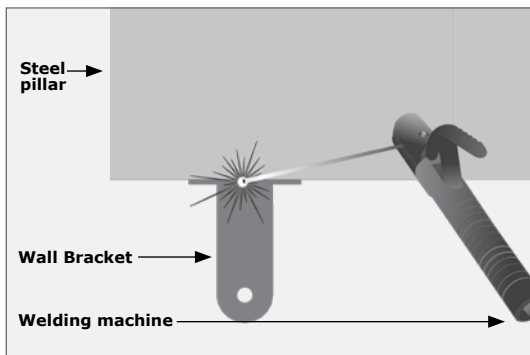

FIGURE 12

6.7.4. Sleeve Anchors

Applications:

- Lighter gates
- Domestic

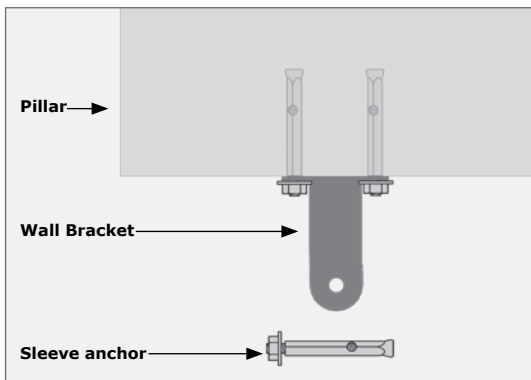

FIGURE 13. SLEEVE ANCHORS

6.7.5. Rawl bolts

Applications:

- Lighter gates
- Domestic

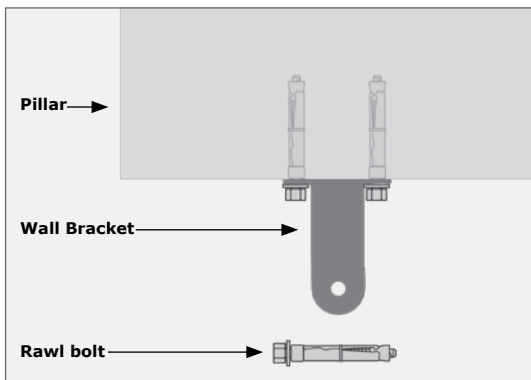

FIGURE 14. RAWL BOLTS

6.8. Gate Bracket Mounting

6.8.1. Steel Gates

The Gate Bracket is designed to be welded onto the gate.

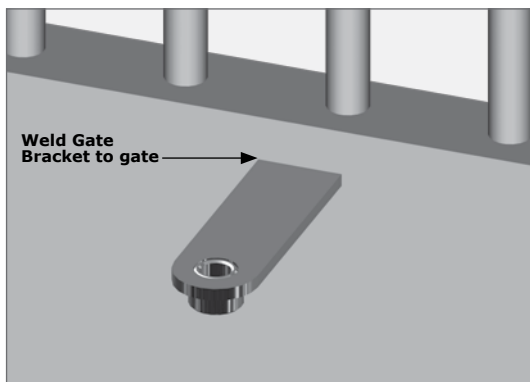

FIGURE 15. WELD GATE BRACKET TO GATE

6.8.2. Non-Steel Gates

In the case where the gate is not manufactured from steel:

- Use a suitable bracket made up from steel so that the Gate Bracket can be welded to it and then fastened to the gate using an appropriate method, OR
- Another Wall Mounting Bracket can be purchased and then the Gate Bracket can be welded to it as shown in Figure 16.

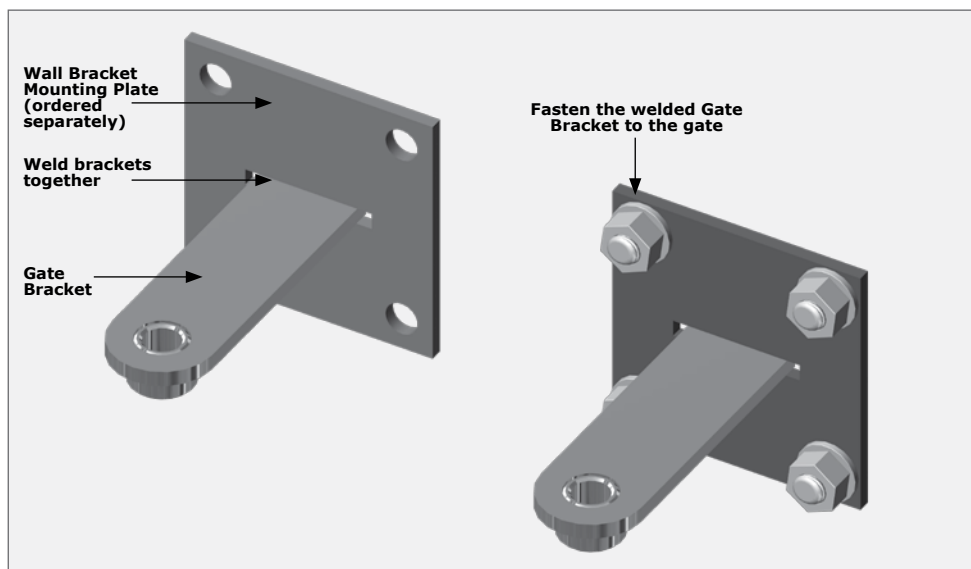

FIGURE 16. MOUNTING THE GATE BRACKET TO A NON-STEEL GATE

7. Cabling Requirements

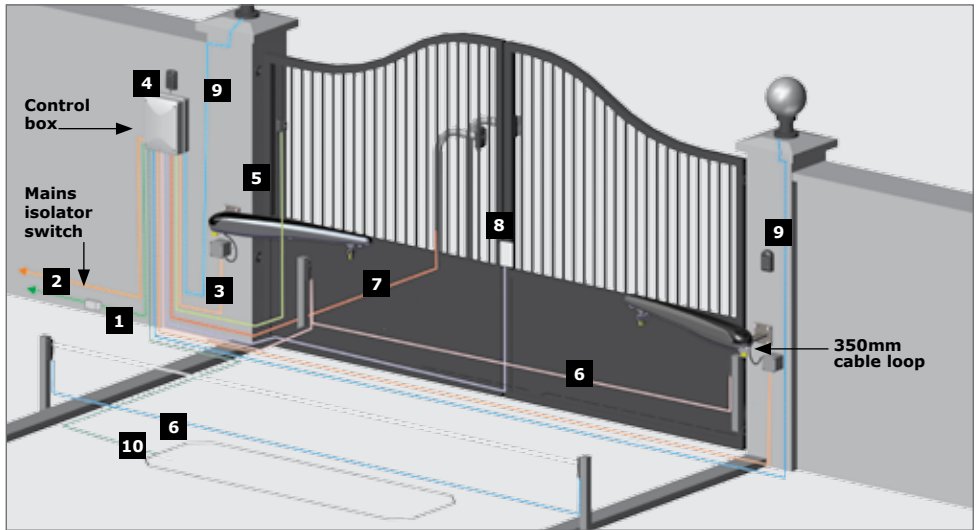

FIGURE 17. CABLING REQUIREMENTS

Legend

1. 90V - 240V AC mains cable via mains isolator¹ switch (3 core LNE 0,5mm²)², or low-voltage 16V AC battery charger supply³ (2 core 1,5mm²).
2. Intercom cable (n1 + 6 core) to house.
3. Master motor (MTR M) or Slave motor (MTR S) cable. (Minimum, 2 core 1.5mm² + 4 core 0,22mm² multi-stranded)⁴.
4. Optional radio receiver cable (3 core 0,5mm² multi-stranded, optional)⁵.
5. Optional Pedestrian Keyswitch (2 core 0,5mm² multi-stranded) or optional keypad (3 core 0,5mm² multi-stranded).
6. Optional, but recommended Infrared Safety Beams (3 core 0,5mm² multi-stranded or 4 core 0.5mm² for CE compliance).
7. Optional intercom cable (n2 + 2 core 0,5mm² multi-stranded) to gate station.
8. Optional electric lock (2 core 0.5mm²).
9. Optional Pillar Light cable (3 core, size according to power regulations).
10. Optional ground loop for free-exit (1 core 0.5mm² multi-stranded - silicone-coated)⁶.

1. As per SABS/IEC 10142 Electrical Regulations the mains isolator must be fitted less than 1.5m from the controller
2. Increase cable thickness if Pillar Lights are to be installed
3. Screened cable is always recommended to provide better protection against lightning - earth one end of screening
4. Please use V-Series cabling. Order reference: CABLEVEC68
5. For optimum range an external receiver can be mounted on the wall
6. Consult manufacturer of loop detector for specific details



- **All cables must be routed in conduit unless underground cable is being used**
- **Mains isolator must be less than one metre from the operator**
- **Safety Beams are always recommended**

8. Critical Installation Checklist

The following is a list of critical requirements that must be adhered to in order to ensure reliable operation of your **VERT-X** operator(s):

- Ensure that the Wall Bracket is securely anchored
- Make sure that the operator's maximum stroke is being utilised
- Only use V-Series cable for the installation
- Leave a 350mm long loop in the cable close to the operator. See Figure 17
- Fit an electric gate lock if the gate leaf width is greater than 2.5 metres
- Ensure that the opening and closing angles conform to the installation guidelines
- Ensure that your gate and operator(s) are equipped to deal with Wind Loading (refer to the Table 4 on page 14)



Never run the operator directly from the battery! Doing so will cause damage to the operator and invalidate the warranty. Only run the operator from the V-Series Controller.

9. Operator Installation-Inward Opening Gate

9.1. Key Terms Used in this Section

- A-Value:** The horizontal distance from the pivot point on the Wall Bracket to the gate hinge point
- B-Value:** The vertical distance from the pivot point on the Wall Bracket to the gate hinge point
- C-Value:** The horizontal distance from the gate hinge point to the Gate Bracket pivot point
- D-Value:** The distance from the gate center line to the pivot point on Gate Bracket welded assembly
- E-Value:** The distance from the face of the gate to the pivot point on the Gate Bracket welded assembly

9.2. Installation Tables - Inward Opening

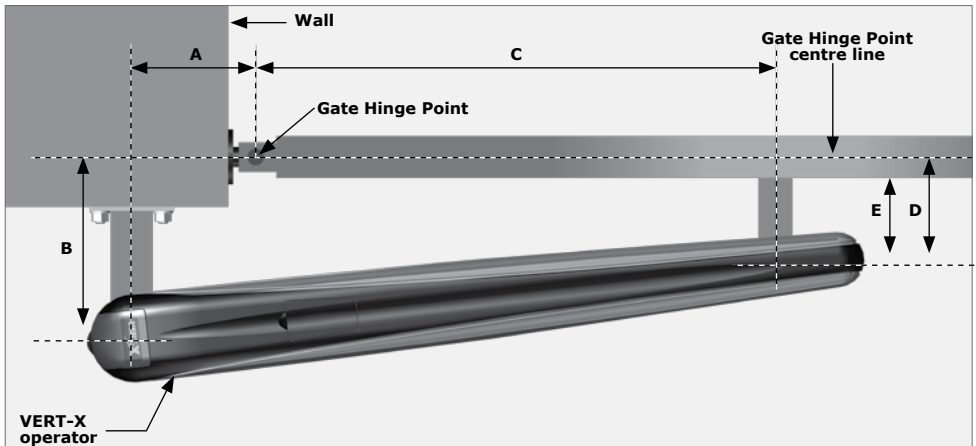

FIGURE 18. BRACKET POSITION - INWARD OPENING GATE

Use the following installation tables to determine the best geometry for the installation.

VERT-X Inward Opening Geometry Tables:

90° Inward Opening Gate

| E-Value | A-Value | B-Value | C-Value | D-Value |
|---------|--------------------|--------------------|--------------------|--------------------|
| >80mm | 140mm ¹ | 160mm ¹ | 638mm ¹ | 110mm ¹ |
| >82.5mm | 150mm | 150mm | 628mm | 110mm |
| >85mm | 160mm | 140mm | 618mm | 110mm |

1. Optimum Installation

TABLE 6

100° Inward Opening Gate

| E-Value | A-Value | B-Value | C-Value | D-Value |
|-------------------|--------------------------|--------------------------|--------------------------|--------------------------|
| >77.5mm | 150mm¹ | 140mm¹ | 633mm¹ | 110mm¹ |
| >82.5mm | 160mm | 135mm | 626mm | 110mm |

1. Optimum Installation

TABLE 7

With this type of operator, it is critical to choose the correct installation position from the installation tables to ensure that the tip of the operator does not interfere with the gate during operation.

9.3 Physical Installation - Inward Opening

9.3.1. Step 1: Determine the Gate Bracket Length (E-Value)

It is essential to first determine whether the correct Gate Bracket length (E-Value) can be achieved according to Table 9 (Installation Table) as described below.

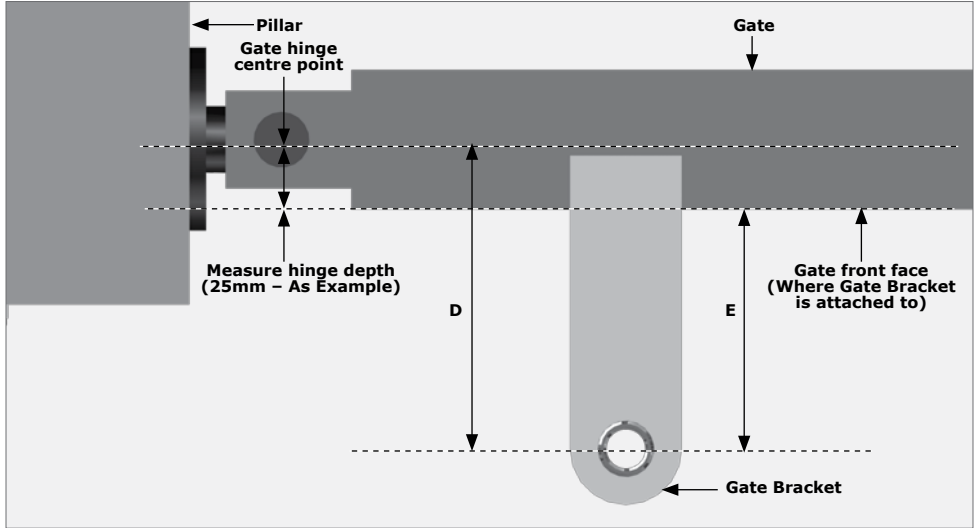

FIGURE 19. DETERMINE THE GATE BRACKET LENGTH

Example for a 90° Inward Opening Installation

Measure the hinge depth from the centre of the hinge point to the face of the gate.

If the hinge depth is greater than 30mm, then refer to Section 6.6.

For this example, a measurement of 25mm will be used.

E-Value = D-Value MINUS Hinge Depth.

Thus: E-Value = 110mm - 25mm = 85mm.

If the E-value is greater than 85mm, you may choose any installation position shown in Table 6.

If the E-Value is less than 80mm (for 90° inward opening) or less than 77.5mm (for 100° inward opening), the operator WILL foul against the gate during operation as shown in Figure 9. In order to rectify this, refer to Section 6.6.

9.3.2. Step 2: Wall Bracket Height

Determine a suitable height for the Wall Bracket.

Be aware that the Wall Bracket is mounted 35mm higher than the Gate Bracket. If the gate has limited cross-bars to which the Gate Bracket can be attached, then this will determine the height of the Wall Bracket.

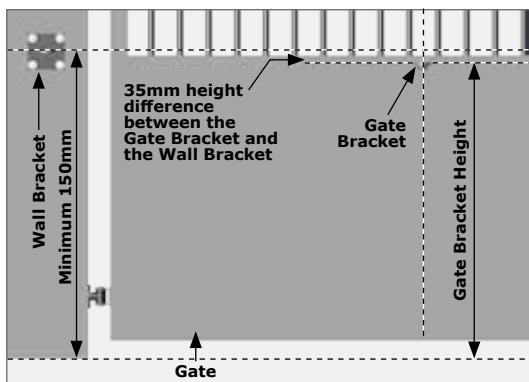

FIGURE 20. WALL BRACKET HEIGHT

9.3.3. Step 3: Mounting the Wall Bracket

9.3.3.1. Determine the Wall Bracket Length

From Figure 18 and Table 6 find the corresponding B-Value for the installation determined in Section 9.3.1.

Using a steel ruler (tape measure) or the VERT-X ABS template (which can be purchased as an optional extra, determine the Wall Bracket length.

For the steel ruler option, this is achieved by placing the steel ruler with the 0mm marking at the gate hinge point and measuring out the B-Value. The Wall bracket length is then the difference between the B-Value and the distance to the pillar face. This is shown in Figure 21.

For the VERT-X ABS template option, place the correct B-Value measurement at the gate hinge point. The Wall Bracket length is determined by measuring the distance from the horizontal line on the template to the pillar face. This is shown in Figure 22.

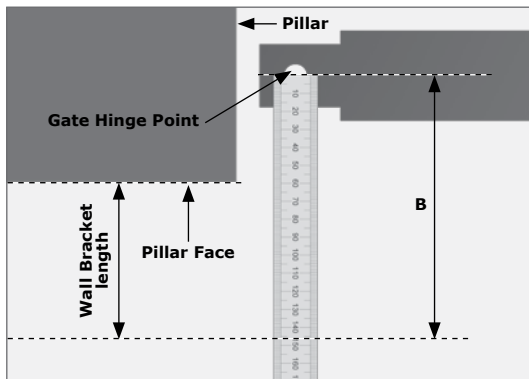

FIGURE 21. DETERMINE WALL BRACKET LENGTH (USING A RULER)

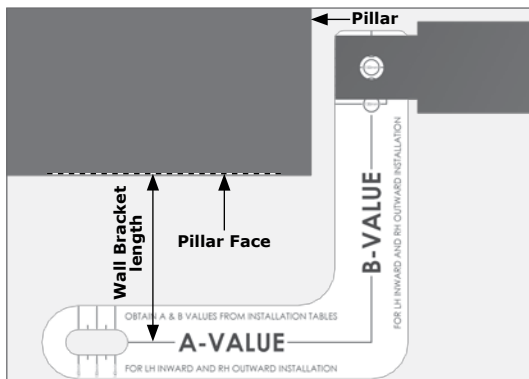

FIGURE 22. DETERMINE WALL BRACKET LENGTH (USING THE ABS TEMPLATE)

9.3.3.2. Cut and Weld the Wall Bracket

Mark the determined length on the Wall Bracket.



Measure the determined length from the centre of the hole.

Cut off excess length.

Insert the Wall Bracket into the mounting plate.

Weld the brackets together.

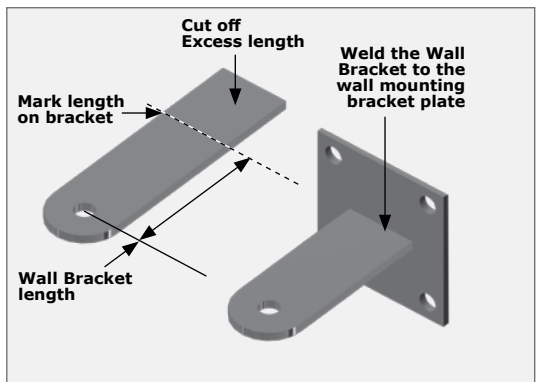

FIGURE 23. CUT AND WELD THE WALL BRACKET

9.3.4. Step 4: Mounting the Wall Bracket Assembly

From Figure 18 and Table 6 find the corresponding A-Value for the installation determined in Section 9.3.

Using a steel ruler (tape measure) or the **VERT-X** ABS template, determine the mounting position of the Wall Bracket.



Ensure that the measurement is taken to the centre of the hole as shown in Figures 24 and 25.

Mark the Wall Bracket in the correct position on the wall and then mount it using the preferred mounting method as discussed in Section 6.5.

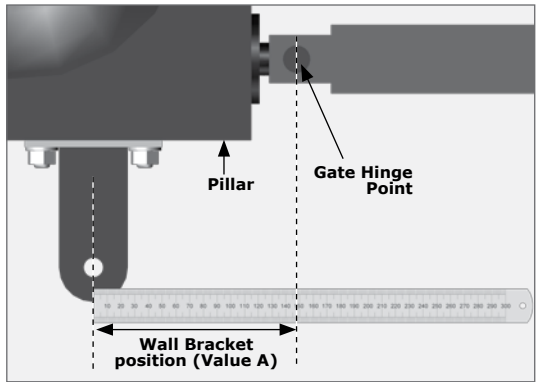

FIGURE 24. DETERMINE WALL BRACKET POSITION (USING A RULER)

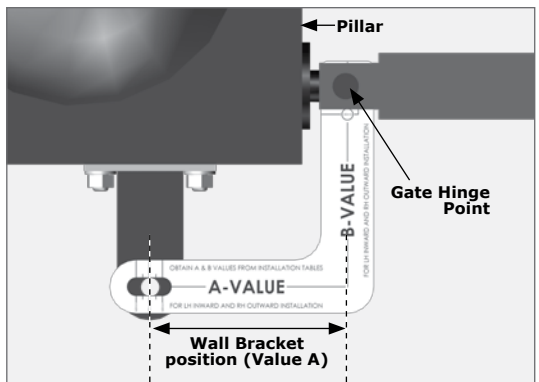

FIGURE 25. DETERMINE THE WALL BRACKET POSITION (USING THE ABS TEMPLATE)

9.3.4.1. Cutting the Gate Bracket

Determine the E-Value for this specific installation by following the example in section 9.3.1 and substituting the hinge depth of this specific installation into the calculation.

Cut the Gate Bracket to the E-Value length in order to mount the bracket to the gate and achieve the correct D-Value.



The measurement is taken from the centre of the hole of the Gate Bracket as indicated in Figure 26.

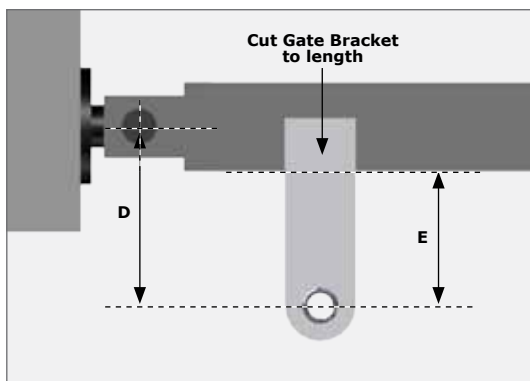

FIGURE 26. CUT THE GATE BRACKET

9.3.4.2. Making Up a Bracket for a Non-steel Gate

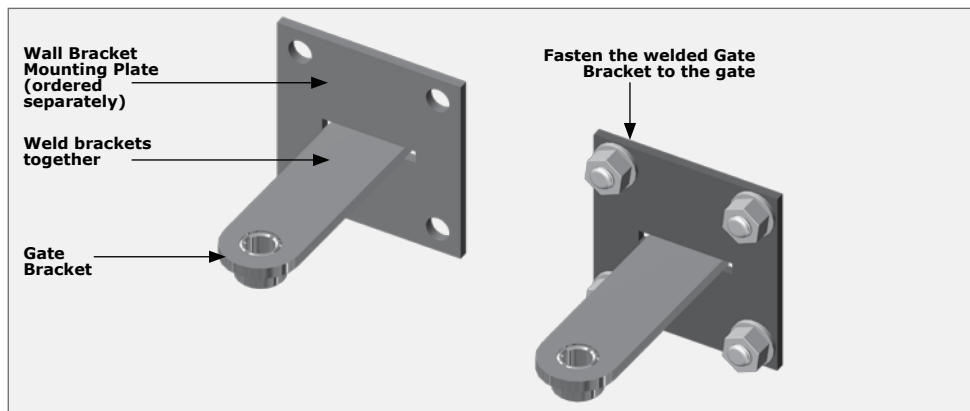

FIGURE 27. ATTACH THE GATE BRACKET ONTO A NON-STEEL GATE

In the case where the gate is not manufactured from steel or the mounting point for the front bracket is not on a steel section of the gate, it is necessary to make up a mounting bracket for the Gate Bracket. This is easily achieved by purchasing a second Wall Mounting Bracket and welding the Gate Bracket to the Wall Bracket Mounting Plate.

9.3.5. Step 5: Mounting the Gate Bracket



Although the installation is easier when using the **VERT-X** Metal Template (which can be purchased as an optional extra), it is possible to install the unit without the use of the template.

9.3.5.1. VERT-X Metal Template

From Figure 18 and Table 6 find the corresponding C-Value for the installation determined in Section 9.3.1.

Close the gate leaf and mark the C-Value distance along the gate leaf (measured from the Gate Hinge Point).

Refer to Figure 28 for details.

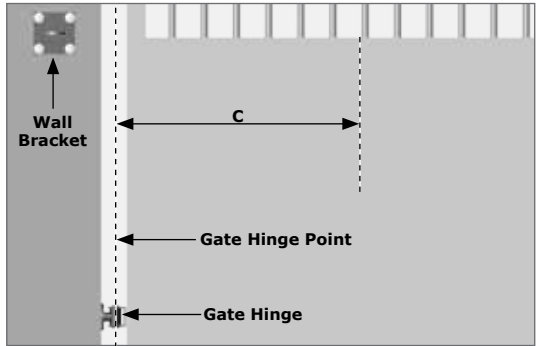

FIGURE 28. MARK THE C-VALUE



- **The operator should never be run manually directly off of a battery! Doing so and driving the operator into an endstop will result in serious damage being sustained by the worm drive**
- **Never lubricate the worm drive**

Mount the operator to the Wall Bracket and, using a spirit level, level the operator and determine the height of the Gate Bracket. Mark the height of the Gate Bracket.

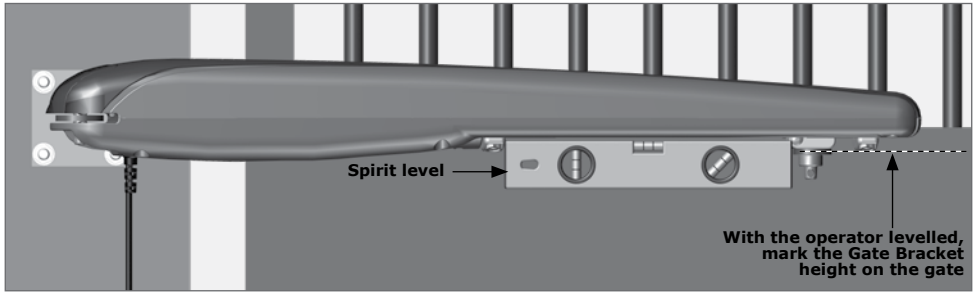

FIGURE 29. MARK THE GATE BRACKET HEIGHT

Remove the operator and then fix the Gate Bracket onto the gate using the preferred mounting method

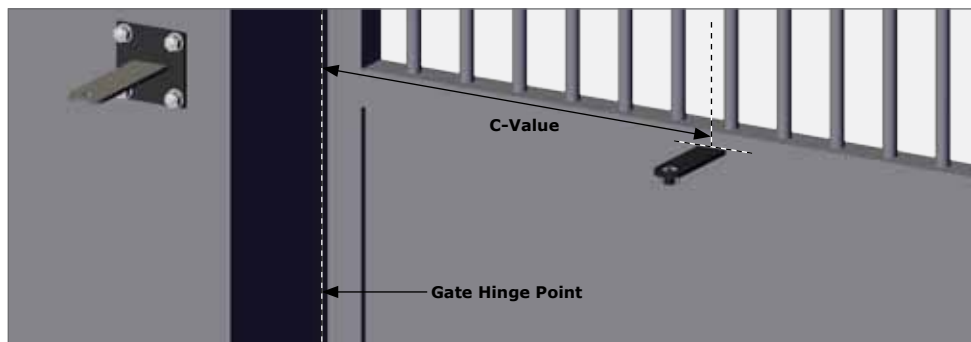

FIGURE 30. ATTACH THE GATE BRACKET ONTO A STEEL GATE

9.3.5.2. Using the Metal Template (Optional Extra)

Using the Metal Template available and the Gate Bracket Pin:

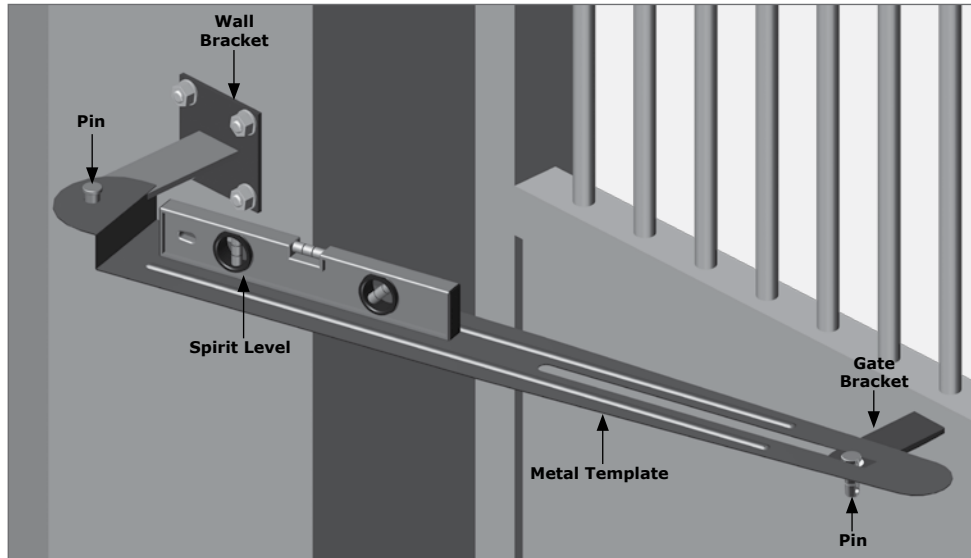

FIGURE 31. MOUNT THE GATE BRACKET

- Mount the template to the Wall Bracket using the bracket pin
- Rest the spirit level on the template and level the template
- Holding the Gate Bracket underneath the template (as shown in Figure 31), insert the pin through the slot in the template and into the Gate Bracket
- With the gate in the closed position, move the Gate Bracket to the end of the slot of the metal template
- Spot weld the Gate Bracket in place OR make the necessary markings if a Bracket has been made up to fit a non-steel gate
- To avoid damage, it is recommended that the Metal Template be removed before the Gate Bracket
- Fix the Gate Bracket onto the gate using the preferred mounting method as discussed in Section 6.6



It is advisable to first check that the installation works before permanently fixing the brackets in place. See section 9.7.

9.3.6. Step 6: Check the Installation if you have the Metal Template

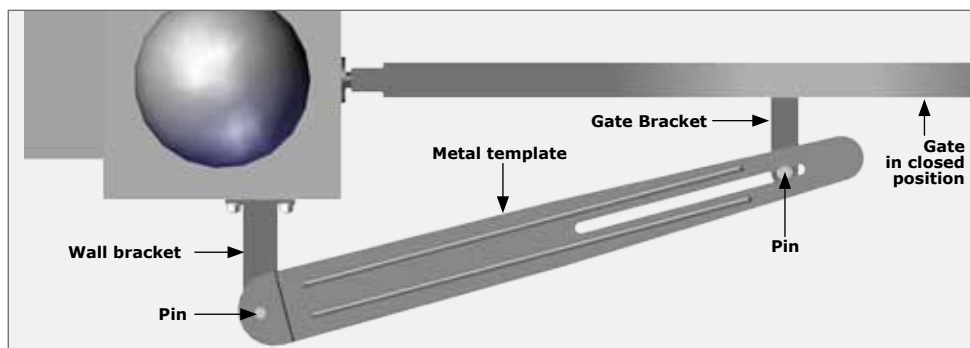

FIGURE 32. GATE CLOSED (METAL TEMPLATE FITTED)

With the Metal Template mounted to the gate as per Section 9.3.6.2., swing the gate leaf to the open position. If it is possible to open the gate to the required open position without the template fouling against the gate pillar or gate, and the Gate Bracket Pin travels within the slot of the Metal Template without fouling, then the installation of the brackets is deemed to be correct.

If you do not have the Metal Template, make sure that the spot welds are sufficient to take a significant load as back-driving the unit through the gearbox in the override condition requires a large force when the unit is new out of the box.

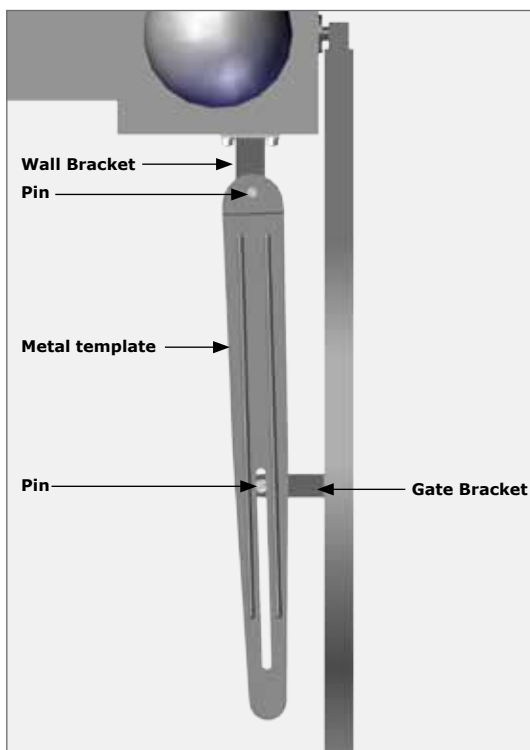

FIGURE 33. GATE OPEN (METAL TEMPLATE FITTED)

9.3.7. Step 7: Mount the Operator

With the brackets now fully fitted, the operator can be mounted onto the brackets.

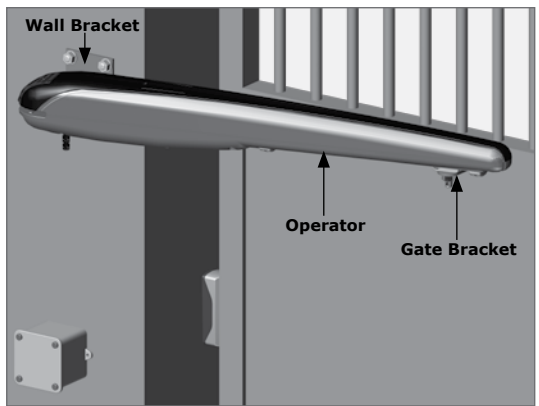

FIGURE 34. OPERATOR MOUNTED

If the unit is mounted onto the brackets and the gate is not in the fully closed position, manually override the unit and move the gate into the closed position.

It may be necessary to adjust the endstops to get to the fully closed and open positions. See section 9.9 for adjusting the endstops.

To place in Manual Override:

- Open the camlock lid to access the override key slot;
- Insert the key and rotate 180°;

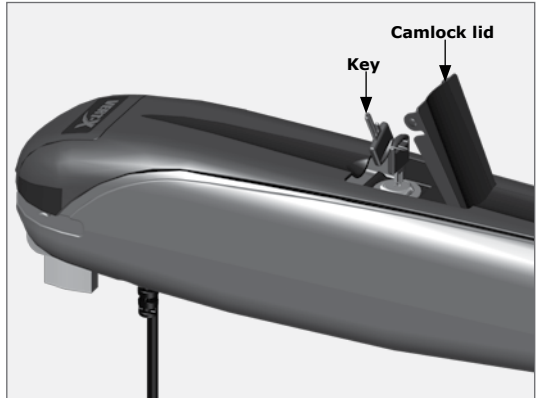

FIGURE 35. HOW TO MANUALLY OVERRIDE THE OPERATOR

9.3.8. Step 8: Adjusting the Endstops

Ensure that the gate is in the fully closed position.

Slightly loosen the Torx screws on front endstop and adjust the endstop so that it sits up against the pivot bracket of the operator. Tighten the Torx screws in this position.



If the gate has mechanical endstops in the closed position, there is no need to adjust the front endstop on the operator.

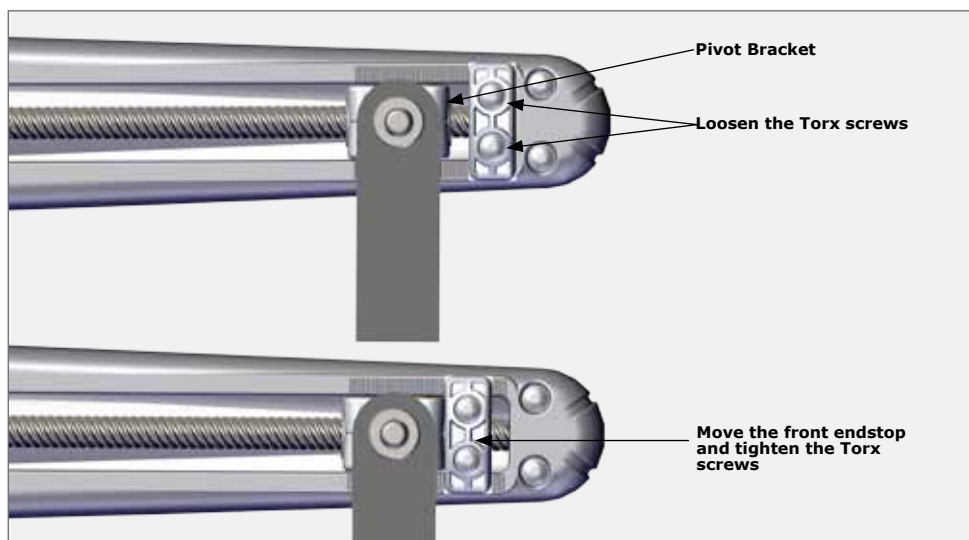

FIGURE 36. ADJUST THE ENDSTOP

With the unit still in the override condition, move the gate leaf into the required open position and adjust the rear endstop in the same way. Once the endstop has been adjusted, close the gate leaf, re-engage the unit and remove the keys. The unit is now ready to be connected to the controller.



- **The operator should never be run manually directly off a battery! Doing so and driving the operator into in an endstop will result in serious damage being sustained by the worm drive**
- **Never lubricate the worm drive**

10. Operator Installation-Outward Opening Gate



- The installation guidelines shown below include the use of the VERT-X ABS template and the VERT-X metal template
- The installation can still be performed without these templates by using a tape measure and spirit level

10.1. Key Terms Used in this Section

A-Value: The horizontal distance from the pivot point on the Wall Bracket to the gate hinge point

B-Value: The vertical distance from the pivot point on the Wall Bracket to the gate hinge point

C-Value: The horizontal distance from the gate hinge point to the Gate bracket pivot point

D-Value: The distance from the gate center line to the pivot point on Gate Bracket welded assembly

E-Value: The distance from the face of the gate to the pivot point on the Gate Bracket welded assembly

10.2. Installation Tables - Outward Opening

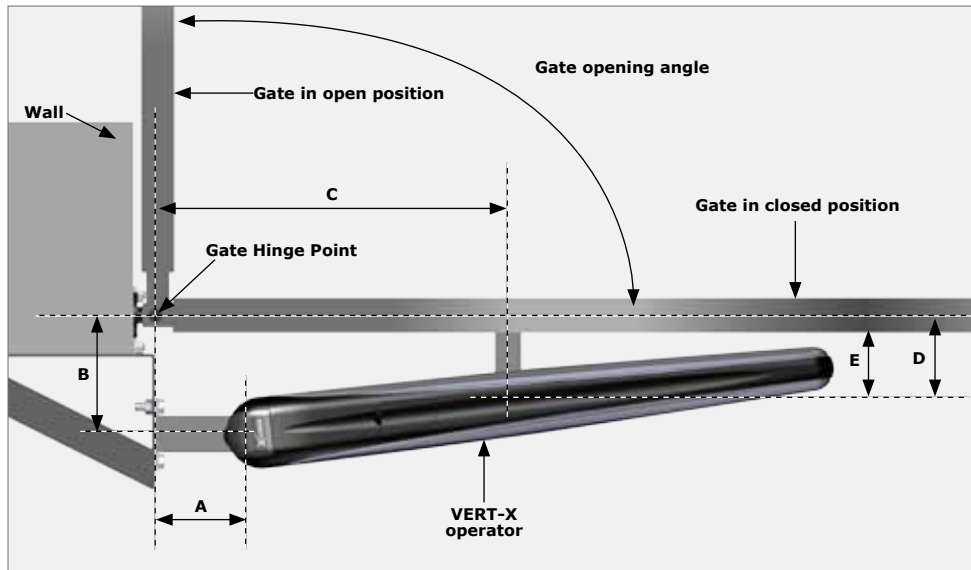

FIGURE 37. OUTWARD OPENING INSTALLATION



In most cases it will be necessary to make up a suitable extension bracket on which to mount the operator's Wall Bracket.

Use the following installation tables to determine the best geometry for the installation.

VERT-X Outward Opening Geometry Tables:

90° Outward Opening Gate

| E-Value | A-Value | B-Value | C-Value | D-Value |
|-------------------|--------------------------|--------------------------|--------------------------|--------------------------|
| >80mm | 140mm | 160mm | 618mm | 115mm |
| >82.5mm | 150mm | 150mm | 628mm | 115mm |
| >82.5mm | 160mm¹ | 140mm¹ | 638mm¹ | 115mm¹ |

TABLE 8

1. Optimum Installation

100° Outward Opening Gate

| E-Value | A-Value | B-Value | C-Value | D-Value |
|-----------------|--------------------------|--------------------------|--------------------------|--------------------------------|
| >85mm | 155mm | 140mm | 633mm | 110mm |
| >85mm | 160mm¹ | 135mm¹ | 630mm¹ | 110 - 115mm¹ |

TABLE 9

1. Optimum Installation



Values- A, B, & C are measured from the gate hinge point.
 Value- D is measured from the gate hinge point centre line.
 Value-E is measured from the gate face to the Gate Bracket centre point.



With this type of operator, it is critical to choose the correct installation position from the installation tables to ensure that the tip of the operator does not interfere with the gate during operation.

10.3. Physical installation - Outward opening

10.3.1. Step 1: Determine the Gate Bracket Length (E-Value)

It is essential to first determine whether the correct Gate Bracket length (E-Value) can be achieved according to Table 8 and 9 (Installation Table) as described below.

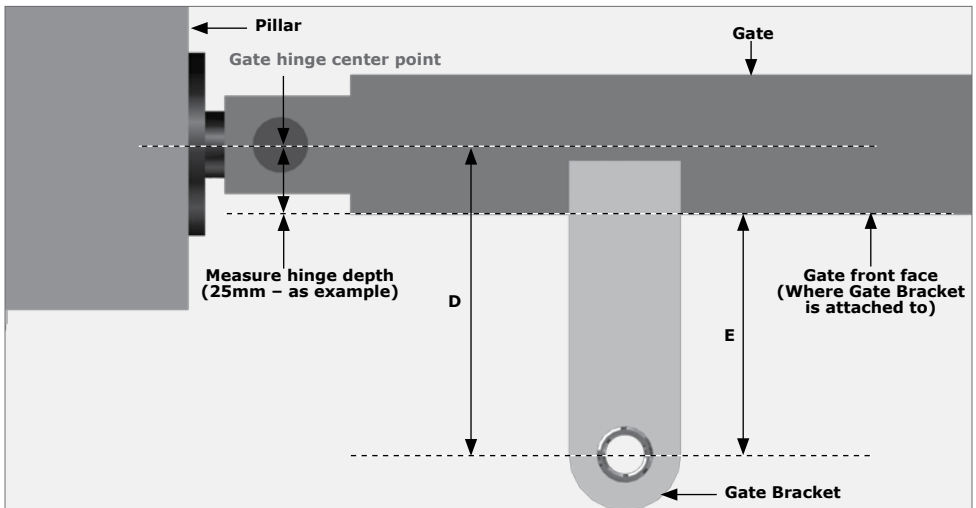

FIGURE 38. DETERMINE THE GATE BRACKET LENGTH

The most optimal installation position for a **VERT-X** 90° outward opening is:

- **A = 160**
- **B = 140**
- **C = 638**
- **D = 115**

Therefore this installation position will be described in this Manual. (Refer to Figure 38 and Tables 8 and 9 for details).

Measure the hinge depth from the centre of the hinge point to the face of the gate. If the hinge depth is greater than 30mm, then refer to Section 6.6. (for this example, a measurement of 25mm will be used).

E-Value = D-Value MINUS Hinge Depth

Thus: E = 115mm - 25mm = 90mm

If the E-value is greater than 82.5mm, you may choose any installation position shown in Table 6 (see note above for optimal installation).

If the E-Value is less than 80mm (for 90° outward opening) or less than 85mm (for 100° outward opening), the operator **WILL** foul against the gate during operation. In order to rectify this, refer to Section 6.4.

10.3.2. Step 2: Wall Bracket Height

Determine a suitable height for the Wall Bracket.

Be aware that the Wall Bracket is mounted 35mm higher than the Gate Bracket. If the gate has limited cross bars to which the Gate Bracket can be attached then this will determine the height of the Wall Bracket.

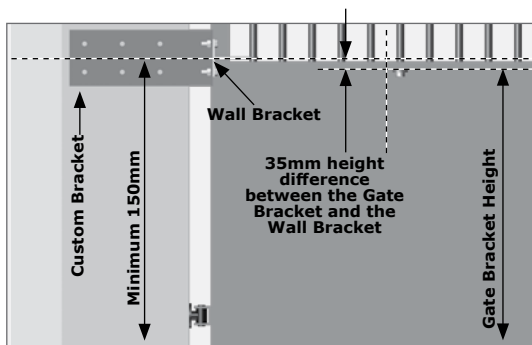

FIGURE 39. WALL BRACKET HEIGHT



In most outward opening installations, a custom bracket will have to be made up by the installer. The **VERT-X** Wall Bracket is then attached to this custom bracket.

10.3.3. Step 3: Mounting the Wall Bracket

10.3.3.1. Determine the Wall Bracket Position

Find the corresponding A-Value and B-Value for the installation determined in Section 10.3.

Using a steel ruler (tape measure) or the **VERT-X** ABS template (which can be purchased as an optional extra), determine the Wall Bracket length.

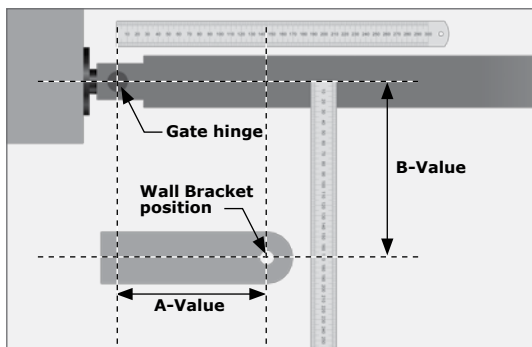

FIGURE 40. DETERMINE WALL BRACKET LENGTH (USING A RULER)

For the steel ruler option, this is achieved by placing the steel ruler with the 0mm marking at the gate hinge point and measuring out the B-Value. The Wall bracket length is then the difference between the B-Value and the distance to the pillar face. This is shown in Figure 40.

For the **VERT-X** ABS template option, place the correct B-Value measurement at the gate hinge point. The Wall Bracket length is determined by measuring the distance from the horizontal line on the template to the pillar face. This is shown in Figure 41

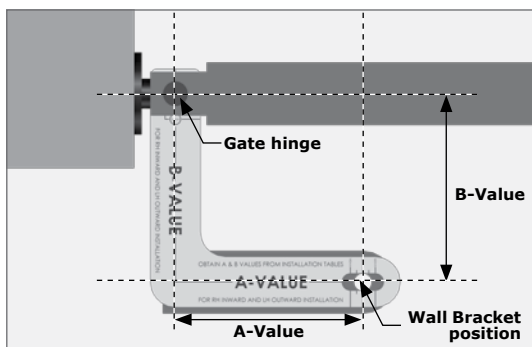

FIGURE 41. DETERMINE WALL BRACKET LENGTH (USING THE ABS TEMPLATE)

10.3.3.2. Make Up and Mount the Custom Bracket

For an outward swing installation, the rear hinge point for the operator needs to be on the inside of the gate hinge. It may be necessary to make up a custom bracket for the installation if it is not possible to mount the bracket to the wall in the case where the side wall is close enough to achieve the correct A-Value. After determining the correct position of the Wall Bracket in Section 10.3.3.1., make up a custom bracket that will securely hold the Wall Bracket in this position as shown in Figure 42A & 42B.

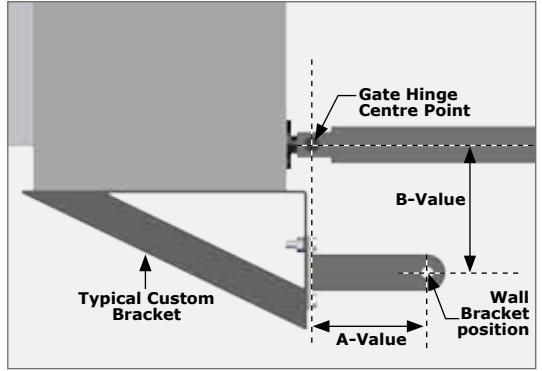

FIGURE 42A. MAKE-UP AND MOUNT CUSTOM WALL BRACKET

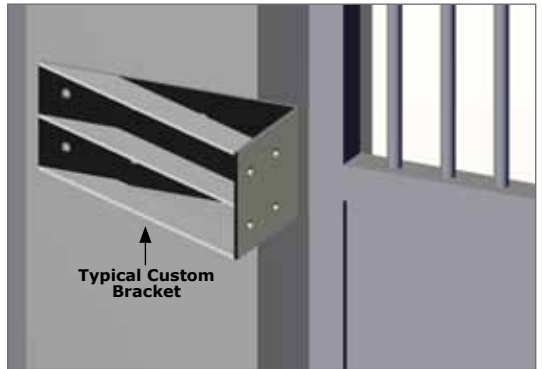



FIGURE 42B. MAKE-UP AND MOUNT CUSTOM WALL BRACKET

10.3.3.3. Cut, Weld and Mount the Wall Bracket

Mark the determined length on the Wall Bracket.

 Measure the calculated length from the centre of the hole as indicated in Figure 43.

Cut off excess length.

Insert the Wall Bracket into the mounting plate.

Weld the brackets together.

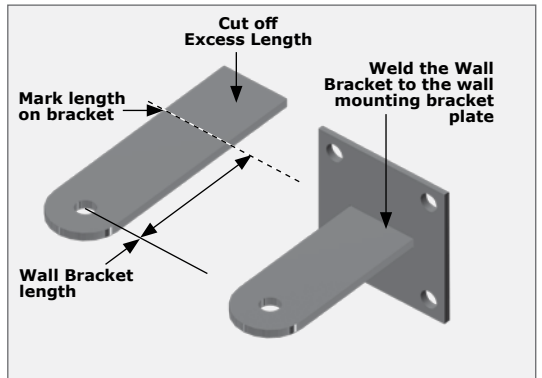

FIGURE 43. CUT AND WELD THE WALL BRACKET

Mount the Wall Bracket in the correct position onto the wall using the preferred method as discussed in Section 6.5 or mount it to the custom bracket as shown in Figure 44.



FIGURE 44. MOUNT THE WALL BRACKET

10.3.4. Step 4: Cutting the Gate Bracket

Determine the E-Value for this specific installation by following the example in section 10.3.1 and substituting the hinge depth of this specific installation into the calculation.

Cut the Gate Bracket to the E-Value length in order to mount the bracket to the gate and achieve the correct D-Value.

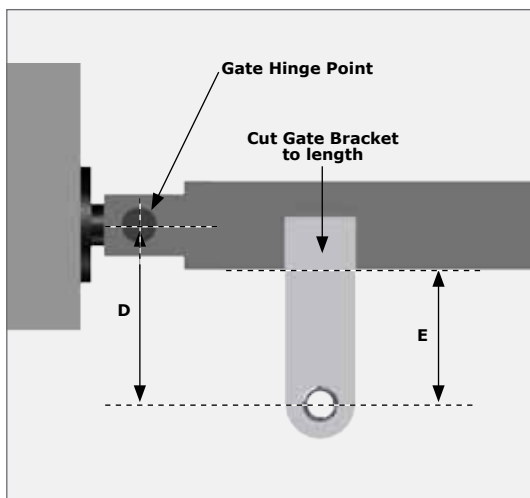

FIGURE 45. CUT THE GATE BRACKET

10.3.4.1. Making Up a Bracket for a Non-steel Gate



In the case where the gate is not manufactured from steel or the mounting point for the front bracket is not on a steel section of the gate, it is necessary to make up a mounting bracket for the Gate Bracket. This is easily achieved by purchasing a second Wall Mounting Bracket and welding the Gate Bracket to the Wall Bracket Mounting Plate. See section 6.6.2

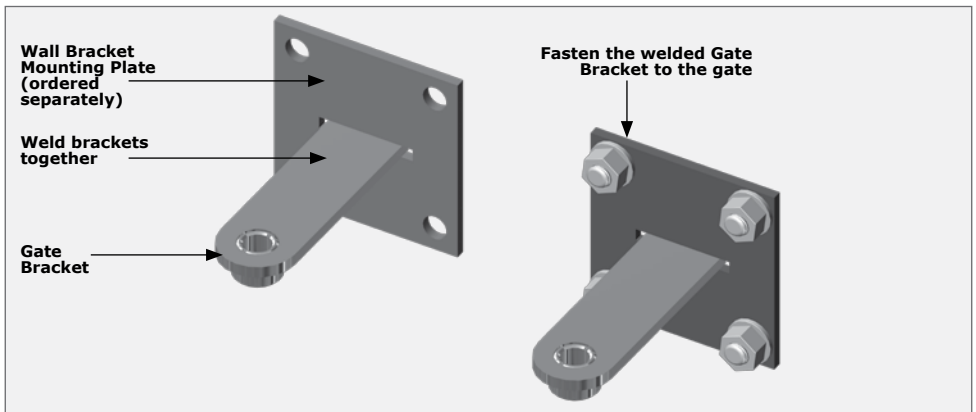

FIGURE 46. ATTACH THE GATE BRACKET ONTO A NON-STEEL GATE

10.3.5. Step 5: Mounting the Gate Bracket



Although the installation is easier when using the **VERT-X** Metal Template (which can be purchased as an optional extra from Centurion Systems), it is possible to install the unit without the use of the template.

10.3.5.1. Without Template

Find the corresponding C-Value for the installation determined in Section 10.2.

Close the gate leaf and mark the C-Value distance along the gate leaf (measured from the centre of the gate hinge).

Refer to Figure 47 for details.

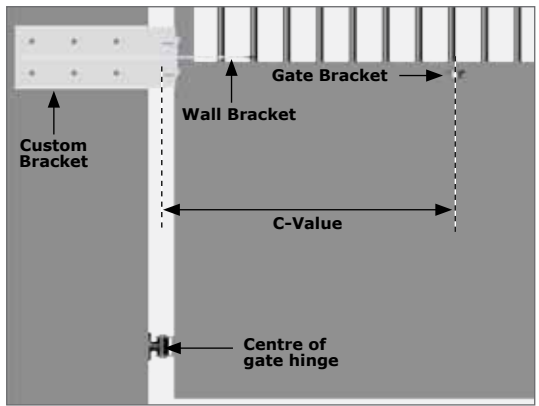

FIGURE 47. MARK THE C-VALUE



- **The operator should never be run manually directly off a battery! Doing so and driving the operator into in an endstop will result in serious damage being sustained by the worm drive**
- **Never lubricate the worm drive**

Mount the operator to the Wall Bracket and, using a spirit level, determine the height of the Gate Bracket. Mark the height of the Gate Bracket.

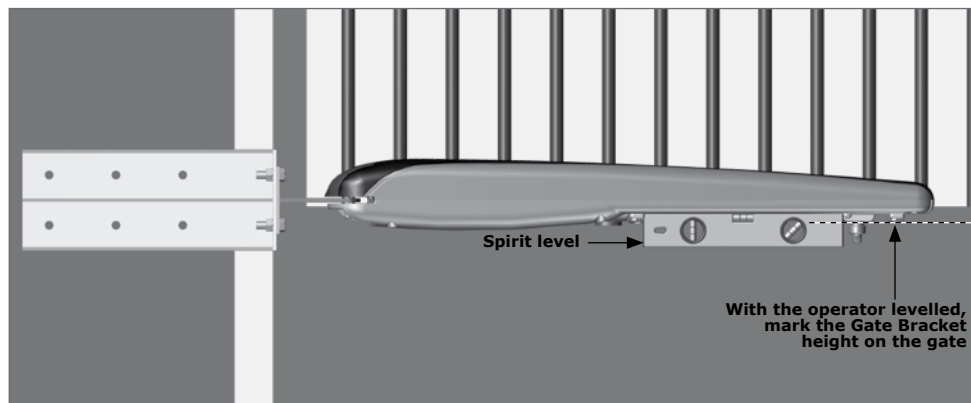

FIGURE 48. MARK THE GATE BRACKET HEIGHT

Remove the operator and then fix the Gate Bracket onto the gate using the preferred mounting method.

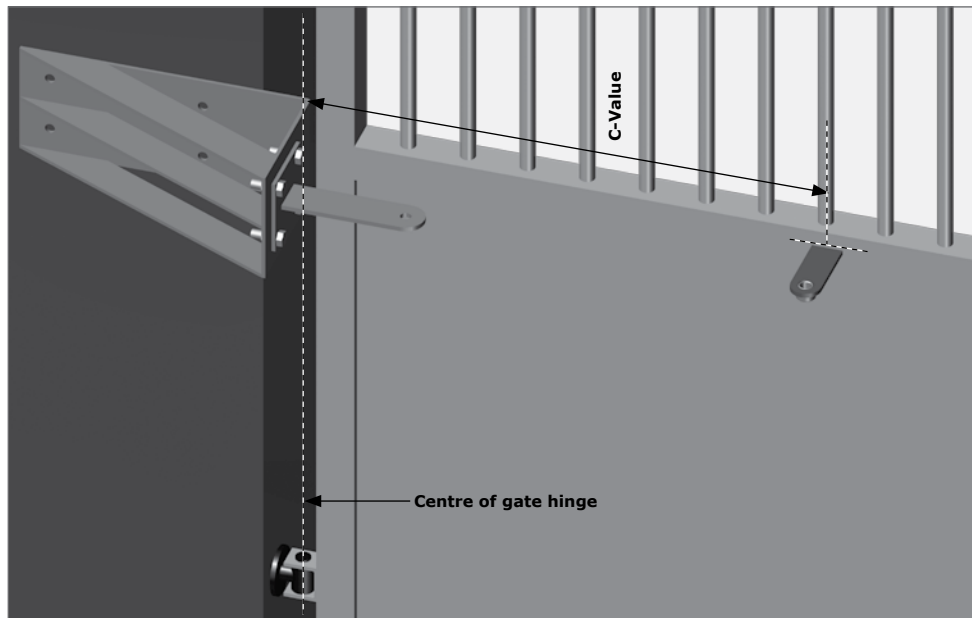

FIGURE 49. ATTACH THE GATE BRACKET IN PLACE



- The operator should never be run manually directly off a battery! Doing so and driving the operator into in an endstop will result in serious damage being sustained by the worm drive
- Never lubricate the worm drive

10.3.5.2. Using the Metal Template (Optional Extra)

Using the Metal Template available and the Gate Bracket Pin:

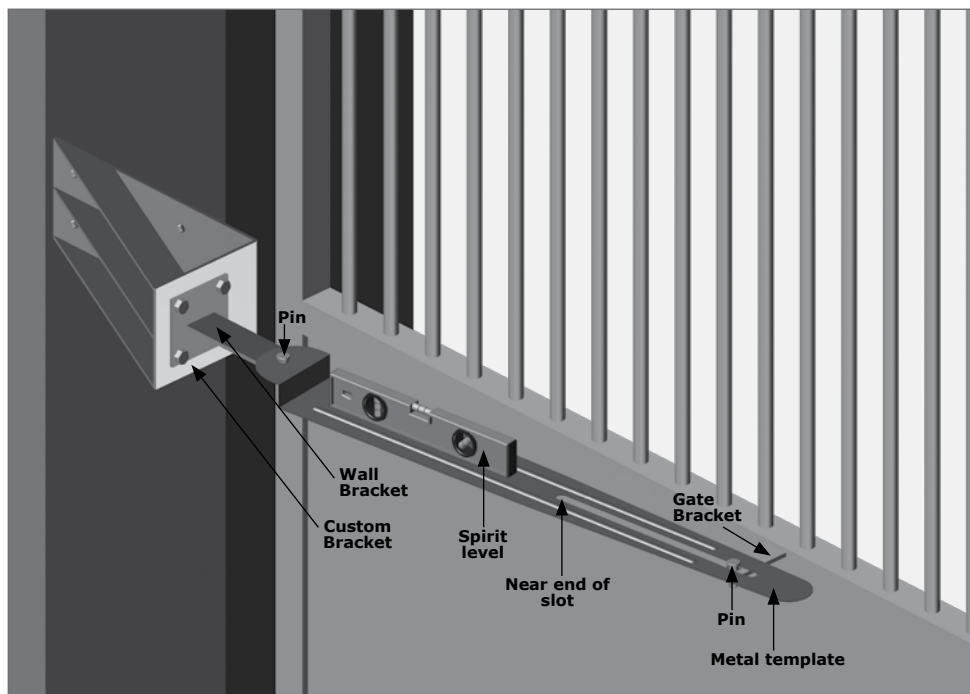

FIGURE 50. MOUNT THE GATE BRACKET

- Mount the template to the Wall Bracket using the Bracket Pin
- Rest the spirit level on the template and level the template
- Holding the Gate Bracket underneath the template (as shown in Figure 50), insert the Pin through the slot in the template and into the Gate Bracket
- With the gate in the closed position, move the Gate Bracket to the near end of the slot
- Spot weld the Gate Bracket in place OR make the necessary markings if a bracket has been made up to fit a non-steel gate
- To avoid damage it is recommended that the Metal Template be removed before the Gate Bracket
- Fix the Gate Bracket onto the gate using the preferred mounting method.



It is advisable to first check that the installation works before permanently fixing the brackets in place. See Section 10.7.

10.3.6. Step 6: Check the Installation if you have the Metal Template

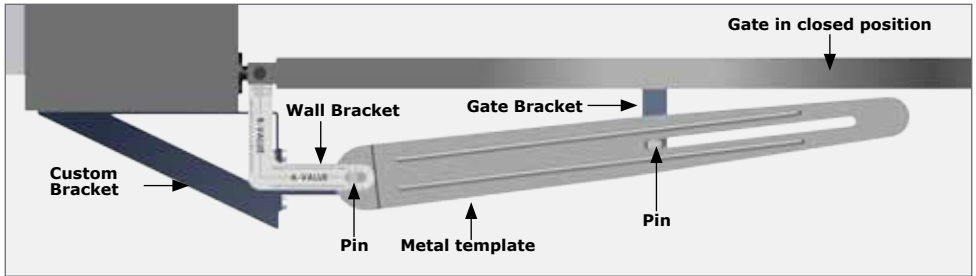

FIGURE 51. GATE CLOSED (METAL TEMPLATE FITTED)

With the metal template mounted to the gate as per Section 10.6.2., swing the gate leaf to the open position. If it is possible to open the gate to the required open position without the template fouling against the gate pillar or gate, and the Gate Bracket Pin travels within the slot of the metal template without fouling, then the installation of the brackets is deemed to be correct.

If you do not have the Metal Template, make sure that the spot welds are sufficient to take a significant load as back-driving the unit through the gearbox in the override condition requires a large force when the unit is new out of the box.

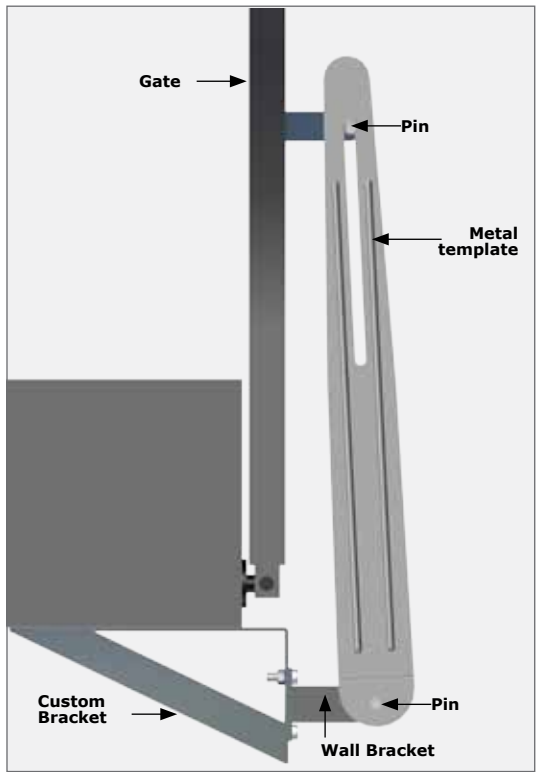

FIGURE 52. GATE OPEN (METAL TEMPLATE FITTED)

10.3.7. Step 7: Mount the Operator

With the brackets now fully fitted, the operator can be mounted onto the brackets.

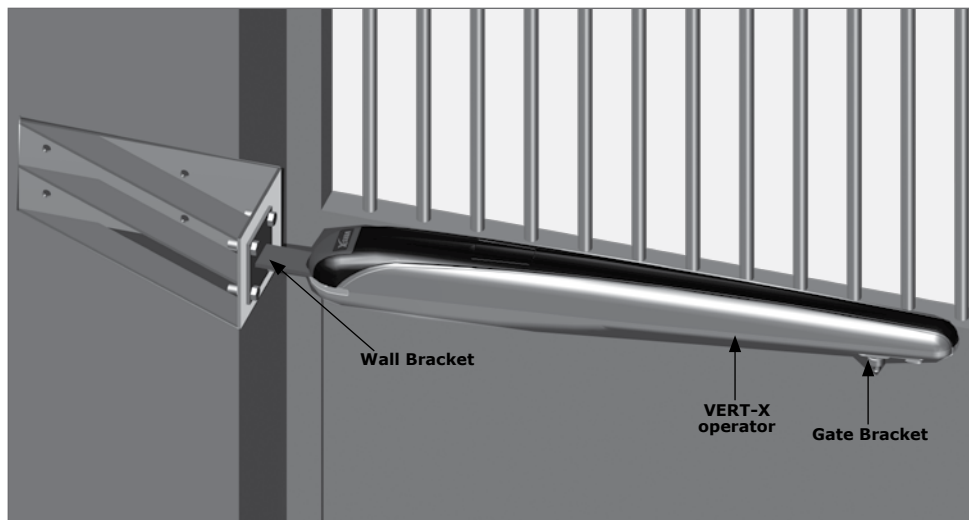

FIGURE 53. OPERATOR MOUNTED

If the operator is mounted onto the brackets and the gate is not in the fully closed position, manually override the unit and move the gate into the closed position.

It may be necessary to adjust the endstops to get to the fully closed and open positions. See section 10.9 for adjusting the endstops

To place in Manual Override:

- Open the camlock lid to access the override key slot;
- Insert the key and rotate 180°;

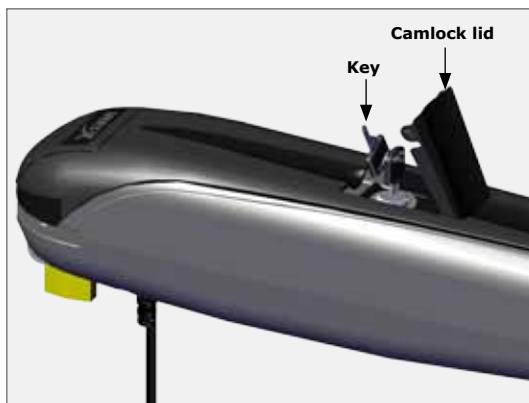

FIGURE 54. HOW TO MANUALLY OVERRIDE THE OPERATOR

10.3.8. Step 8: Adjusting the Endstops

Ensure that the gate is in the fully closed position.

Slightly loosen the Torx screws on the back endstop and adjust the endstop so that it sits up against the pivot bracket of the operator. Tighten the Torx screws in this position.

If the gate has mechanical endstops in the closed position there is no need to adjust the nearest endstop on the operator.

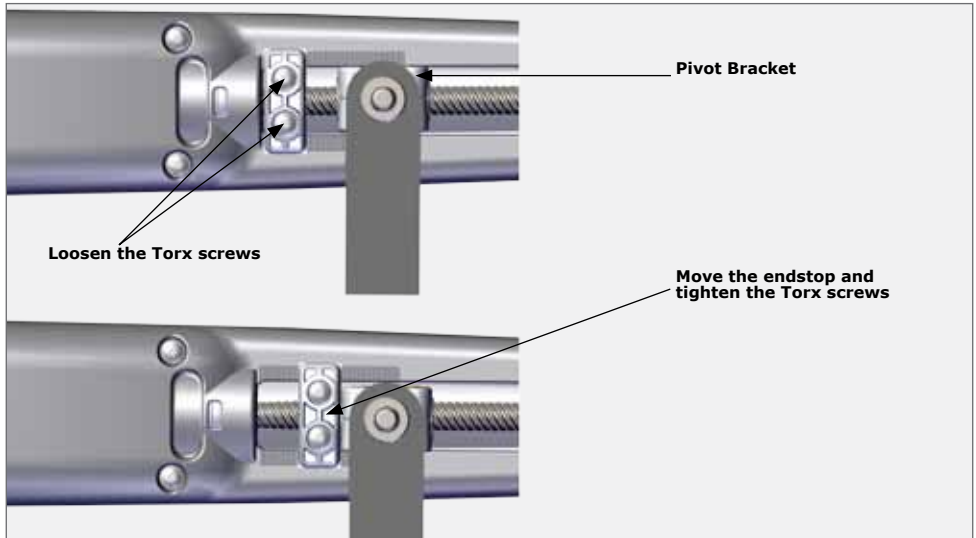

FIGURE 55. ADJUST ENDSTOPS

With the unit still in the override condition, move the gate leaf into the required open position and adjust the front endstop in the same way. Once the endstop has been adjusted, close the gate leaf, re-engage the unit and remove the keys. The unit is now ready to be connected to the controller.



- **The operator should never be run manually directly off a battery! Doing so and driving the operator into in an endstop will result in serious damage being sustained by the worm drive**
- **Never lubricate the worm drive**



Connect with us on:

 facebook.com/CenturionSystems

 YouTube.com/CenturionSystems

 [@askCenturion](https://twitter.com/askCenturion)

Subscribe to the newsletter: www.CentSys.com/Subscribe

Call Centurion Systems (Pty) Ltd • South Africa
Head Office: +27 11 699 2400

Call Technical Support: +27 11 699 2481
from 07h00 to 18h00 (UTC+2)



Document Number: DOC12281V100 -
13032015 - ENGLISH

www.CentSys.com